



FASTCUT



Troncatura e Gole
Shearing - Tronçonnage
Schneidwerkzeuge - Troncadura

Indice **Fastcut**

Sistema Modulare di Scanalatura e Troncatura
Grooving and Parting-off Modular system
Système de tronçonnage modulaire
Modular schneidwerkzeuge
Sistema de ranura y troncatura modular



NEW

CHMN-C...-AB
pag. C 20



NEW

CPML-C...-A
pag. C 21



NEW

CPMR-C...-B
pag. C 22



CHML...34-A
pag. C 23



CPML...34-A
pag. C 24



CCGL...20/30/40/50/60-A
pag. C 25



CCFR...30-A
pag. C 26



CCFR...40-A
pag. C 27



CCFR...50-A
pag. C 28



CCFR...60-A
pag. C 29



CHMR...34-B
pag. C 29



CPMR...34-B
pag. C 30



CCGR...20/30/40/50/60-B
pag. C 33



CCFL...30-B
pag. C 34



CCFL...40-B
pag. C 35



CCFL...50-B
pag. C 36



CCFL...60-B
pag. C 37

Indice **Fastcut**

Troncatura e Gole

Grooving and Parting-off
Tronçonnage et Rainurer
Schneidwerkzeuge
Troncadura y Ranura



LACG...
pag. C 41



CEGR/L...
pag. C 42



CIGR/L...
pag. C 43



CESR/L
pag. C 44



CISR/L...
pag. C 45



PLC...
pag. C 46



SGIH...
pag. C 47



LA...
pag. C 48

Accessori per l'Alta Pressione - High Pressure Accessories - Accessoires Haute Pression Hochdruck-Zubehör - Accesorios de Alta Presión



Accessori Alta Pressione
pag. C 38

Sistema di codifica Utensili Troncatura

Designation code for face grooving holders

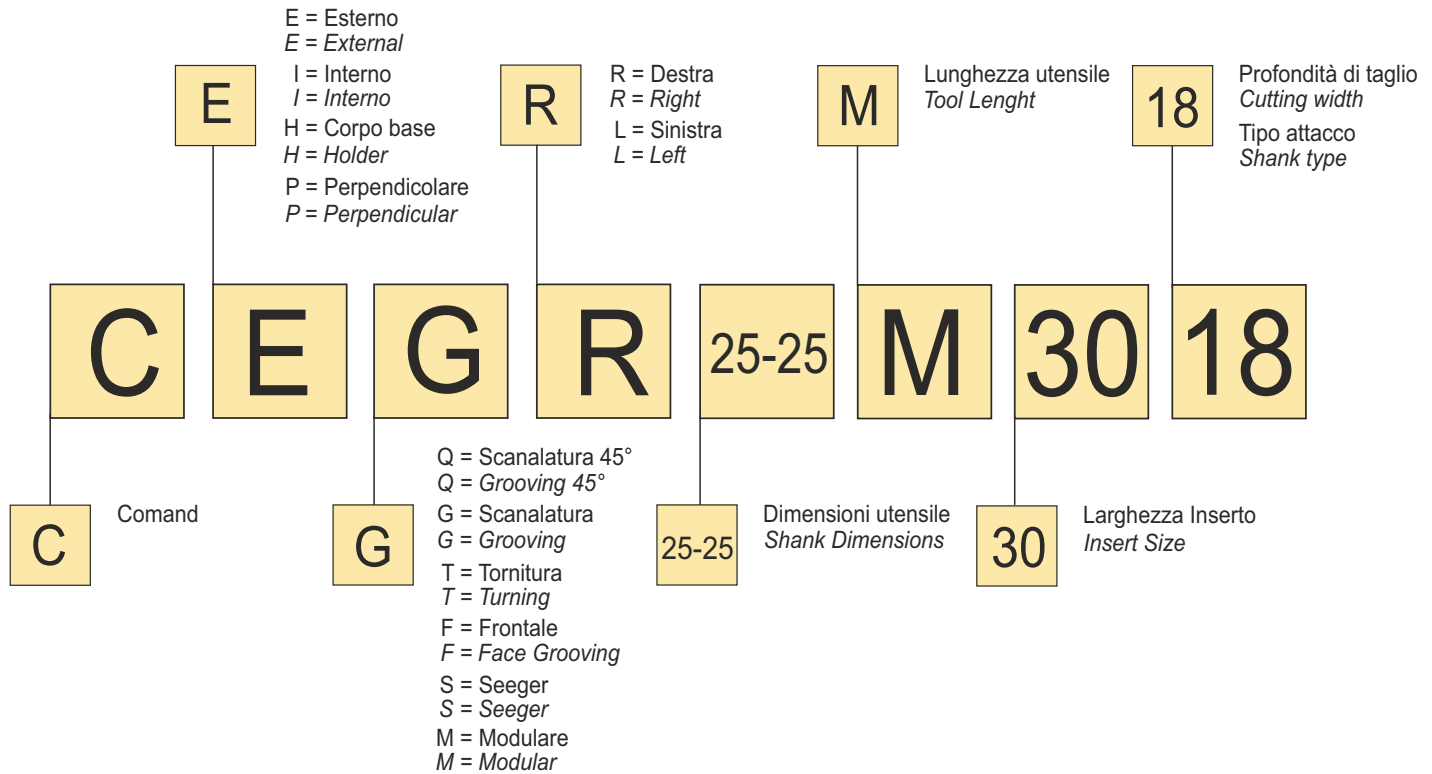

Sistema di codifica Cartucce Troncatura

Designation code for face grooving cartridges

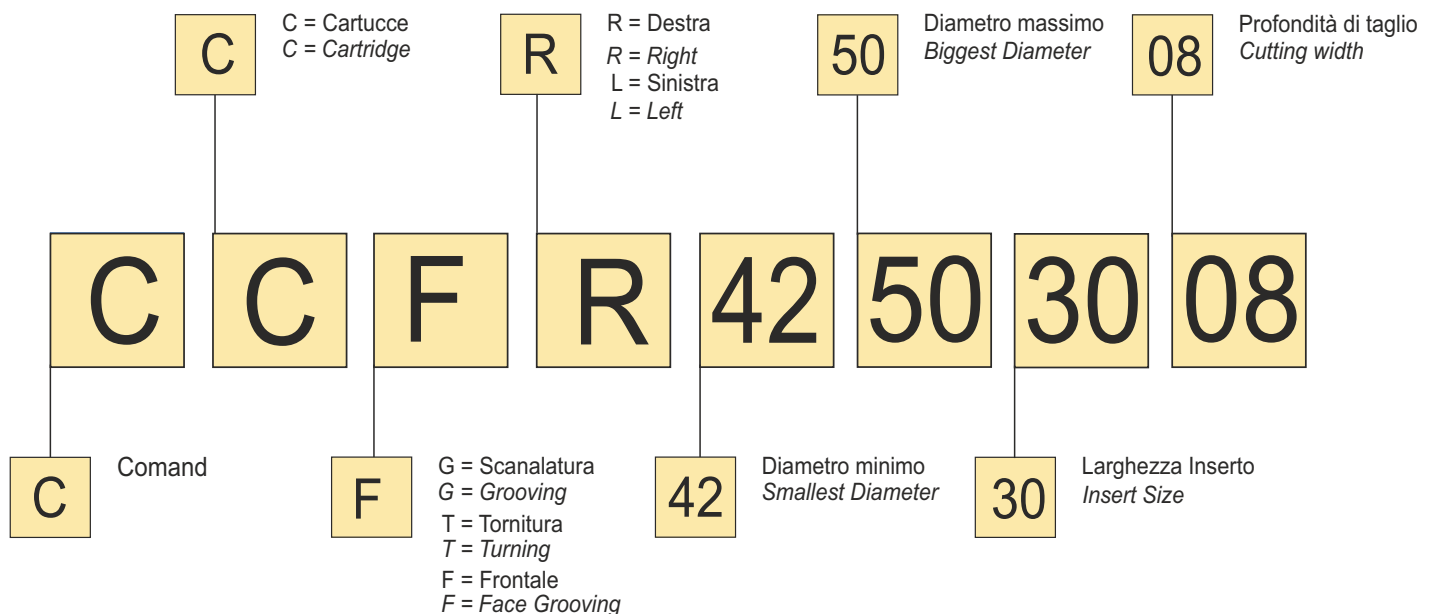

Nuovo Sistema Tornitura, Scanalatura e Taglio

Turning, Grooving and Parting-off New System

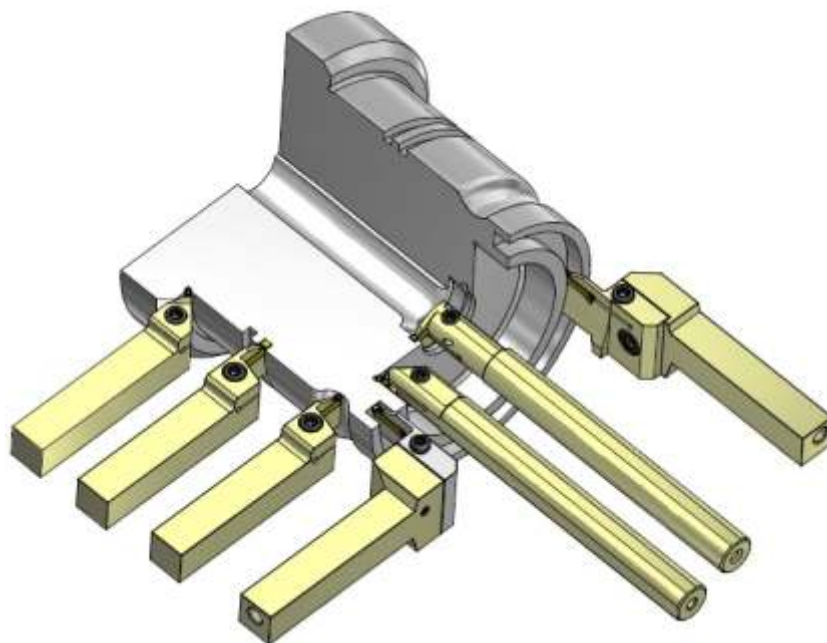

Nuovo Sistema Modulare di Scanalatura Frontale

New Face Grooving Modular System

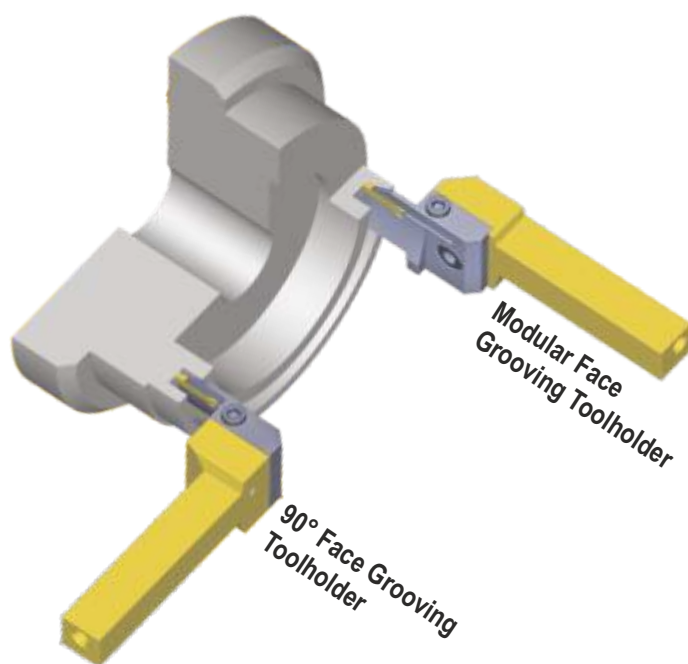

Sistema di troncatura modulare Fastcut

Fastcut Modular Face Grooving System

CHE COS'È

Sistema di posizionamento con sfere calibrate di altissima precisione $\varnothing \pm 1 \mu$ ideato e perfezionato da COMAND TOOL

WHAT IS IT?

High precision cartridge positioning system created by COMAND TOOL. System is based on the use of calibrated spheres (precision $\pm 1\mu$ diameter) for an extremely accurate setting.

A COSA SERVE?

Nato per garantire un perfetto posizionamento della cartuccia senza la necessità di smontare il corpo porta-utensile dalla torretta del tornio.

Massima RIPETIBILITÀ e grande FLESSIBILITÀ nel cambio delle cartucce sul corpo porta-utensile

WHAT IS IT USED FOR?

Designed to allow cartridge change without having to remove the tool from the tool-holder on the lathe turret.

Features great REPEATABILITY and FLEXIBILITY in cartridge type change.

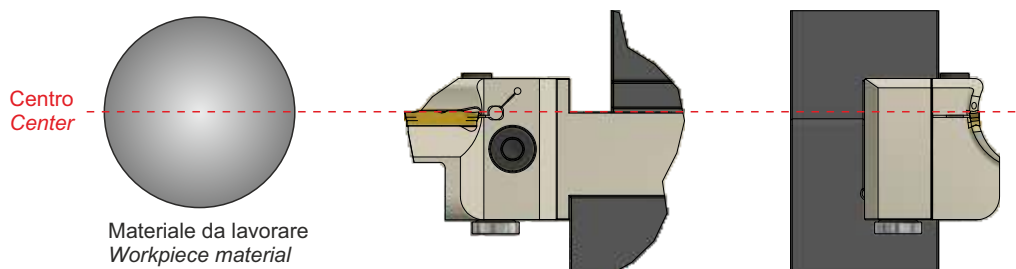

COME FUNZIONA?

Con una sola vite di blocco/sblocco è possibile cambiare la cartuccia mantenendo il corpo in posizione nei portautensili. I vantaggi di questo sistema sono molteplici.

HOW DOES IT WORK?

By acting on a single locking/unlocking screw it is possible to change the cartridge type without losing insert position and alignment. Here are some of the advantages of the system.

Vantaggi / Advantages

- **Posizione costante**
Fixed positioning
- **Ripetibilità garantita**
Guaranteed repeatability
- **Singola vite per montaggio/smontaggio**
Only one locking/unlocking screw
- **FLESSIBILITÀ DI LAVORAZIONE CON CARTUCCE MODULARI**
FLEXIBILITY IN WORKING WITH DIFFERENT MODULAR CARTRIDGES

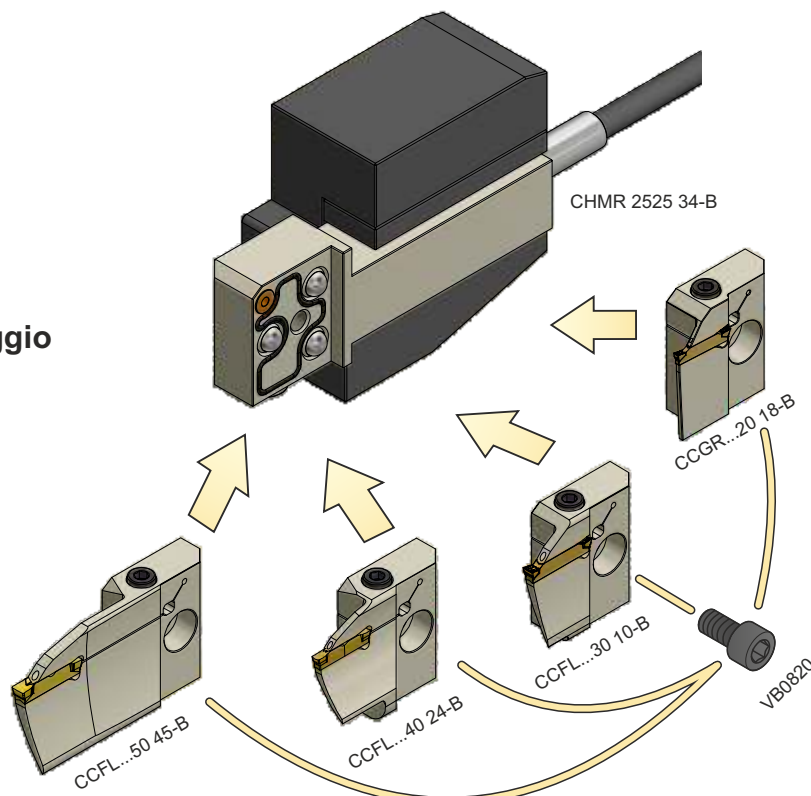

A destra alcuni esempi di diverse cartucce da montare su uno stesso corpo modulare
On the right some examples of different cartridges to be mounted on the same modular holder

O-Ring

Contatto Perfetto / Perfect Contact

Con O-Ring / With O-Ring

O-Ring con durezza calibrata per garantire un perfetto accoppiamento sui tre punti di contatto tra sfere e cartuccia, l'allineamento è sempre preciso. La presenza dell'O-Ring funge anche da elemento smorzante, diminuendo possibili risonanze di lavorazione per una maggiore qualità di finitura.

Calibrated hardness O-Ring guarantees that there are always three contact points between cartridge and tool body for perfect alignment. The O-ring also helps reduce any possible machining vibrations for an improved workpiece quality.

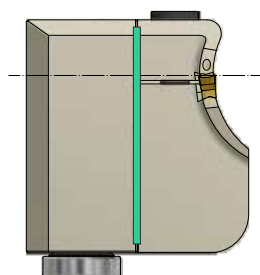

Allineamento perfetto
Perfect alignment

Senza O-Ring / Without O-Ring

Senza O-Ring si correrebbe il rischio di non avere la cartuccia perfettamente allineata con il corpo perché i piccoli residui delle lavorazioni e la polvere impedirebbero il perfetto contatto dei tre punti.

Without O-ring, cartridge and tool-body pairing might be compromised due to chips and machining residue build up in between.

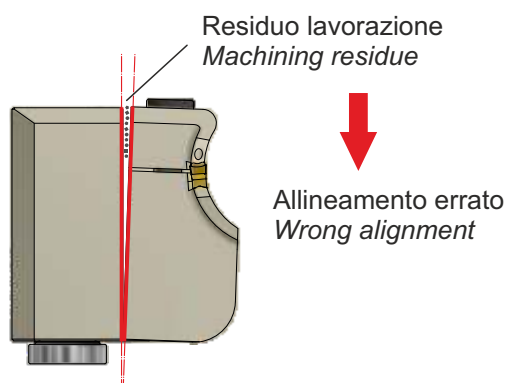

Sistema Refrigerante

Cooling System

Passaggio refrigerante ad alta pressione (fino a 200 bar) per garantire la massima qualità di lavorazione con qualsiasi tipo di cartuccia e inserto utilizzato. Il getto di liquido refrigerante è posizionato in modo da agire sulla punta dell'inserto.

Acqua Stream, high pressure cooling system (up to 200 bar) for maximum machining performance with any kind of cartridge and insert.

Vantaggi del sistema AcquaStream / Advantages of the AcquaStream System

- migliore evacuazione del truciolo
- aumento della qualità di lavorazione
- +200% incremento durata dell'inserto
- temperatura costante
- riduzione dell'attrito sul tagliente dell'inserto
- migliori performance

- improved chip removal
- improved machining quality
- +200% increase of insert life
- constant insert temperature
- reduced friction on the cutting edge
- better performance

Getto d'acqua mirato sul tagliente dell'inserto

Coolant flow aimed at the tip of the insert

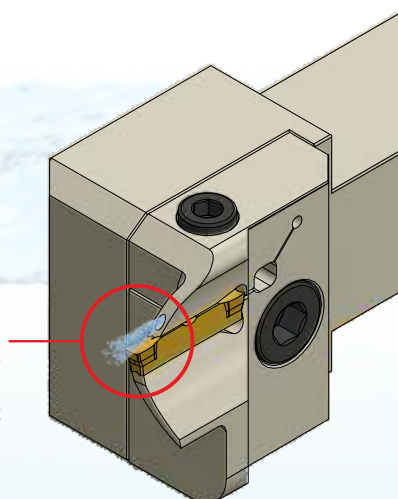



Sistemi di Bloccaggio Inserto / Insert Locking System

Una sede inserto non precisa potrebbe compromettere il corretto inserimento, e conseguente bloccaggio, di un inserto nell'apposita cartuccia o utensile.

Se la sede fosse troppo larga l'inserto avrebbe maggiori possibilità di movimento, andando così a pregiudicarne il posizionamento nel bloccaggio e una corretta lavorazione.

Viceversa, se la sede fosse molto stretta si verificherebbero difficoltà nell'inserimento e nella rimozione dell'inserto.

Insert seat must be very accurate to guarantee perfect positioning and high performance machining.

Insert seat is too wide: increases probability of insert being locked in the wrong position because of positioning tolerances being too large. Insert seat is too tight: difficulty in inserting an extracting insert from cartridge.

Per ovviare a questi inconvenienti in Comand Tool sono stati studiati, progettati e realizzati due sistemi di precisione per l'inserimento ed il bloccaggio dell'inserto:

In order to avoid such problems COMAND TOOL has researched, developed and produced two precision positioning systems:

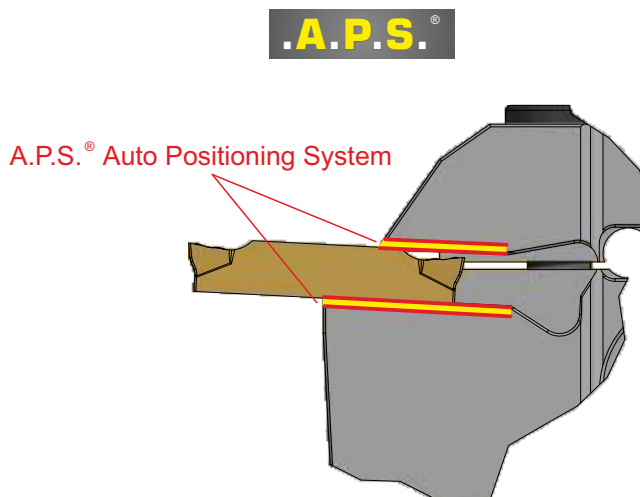
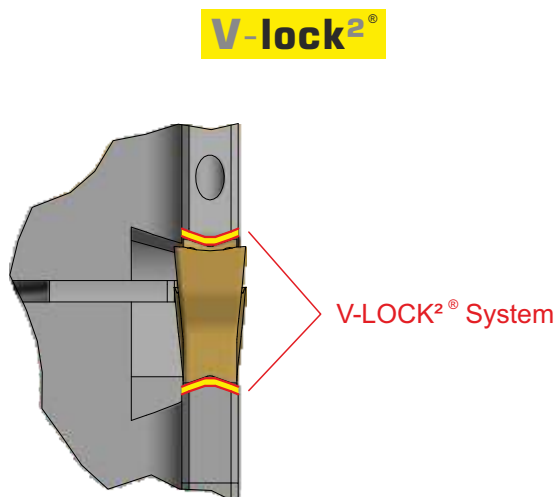

I sistemi progettati da COMAND TOOL hanno i seguenti vantaggi:
COMAND TOOL system has the following advantages:

- Il bloccaggio dell'inserto avviene tramite la vite singola, posta nella parte superiore della cartuccia.
Single screw locking
- Il sistema **V-LOCK²** consente un perfetto bloccaggio ed una precisa angolazione dell'inserto.
V-LOCK² system for perfect insert alignment and angle
- Il sistema **A.P.S. Auto Positioning System**, ideato da COMAND TOOL, fa sì che l'inserto si allinei automaticamente e perfettamente all'interno della sede.
A.P.S. insert seat engineered to guarantee maximum precision and ease during insertion and extraction of insert

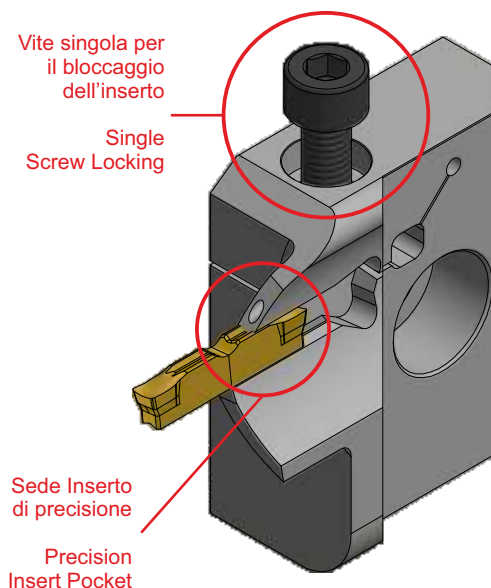



consigli per posizionamento e bloccaggio inserto

A.P.S. System: positioning and locking insert guide

CCG... / CCF... Cartucce / Cartridge

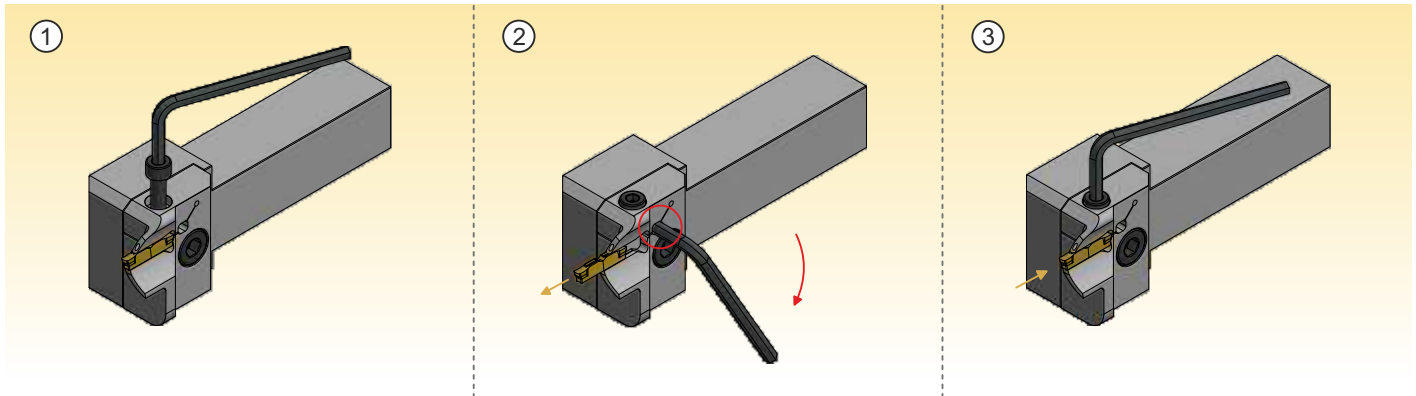

CEG... Utensili per Scanalatura e Troncatura Esterna / Holder for Grooving and Parting-off

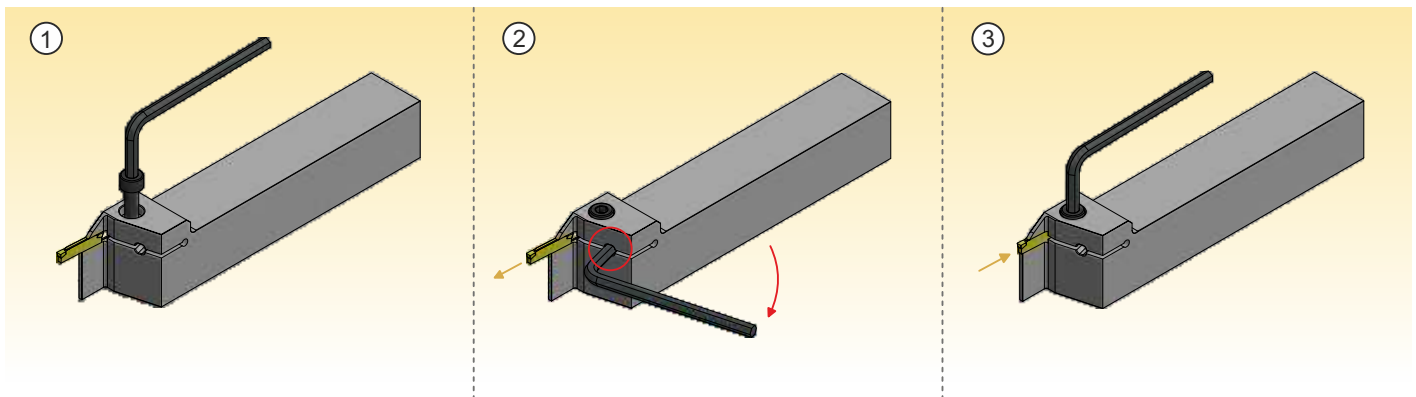

CIG... Utensili per Scanalatura Interna / Holder for Internal Grooving

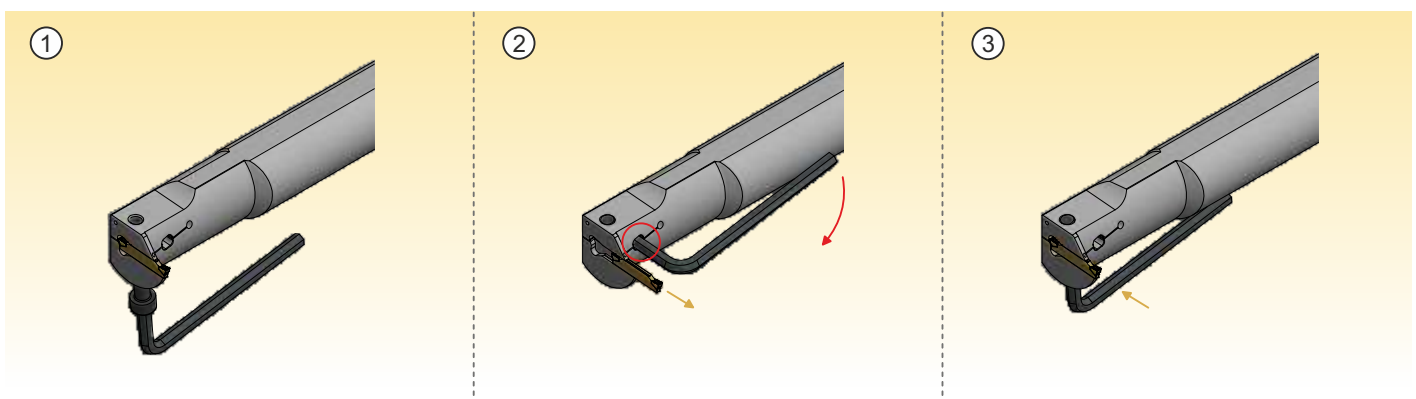

- ① Svitare la vite sopra con l'apposita chiave / *Unlock the top screw using the key provided.*
- ② Posizionare la stessa chiave nella sede. Ruotare la chiave per sbloccare la sede per rimuovere e sostituire l'inserto. *Place the same key in the "pocket." Turn and hold the key to loosen the pocket. Remove and replace the insert.*
- ③ Ora rimuovere la chiave dalla sede e bloccare l'inserto avvitando la vite sopra *Now remove the key from the pocket and secure the insert by firmly locking the top screw.*

Consigli per la Lavorazione di Tornitura Frontale

Modular Face Turning and Grooving machining guide

Pre-lavorazione / Pre-work

1 Scelta dell'utensile

Tool Selection

- 1.1 Utilizzare l'inserto più ampio e l'utensile più largo possibile per ottenere un miglior rapporto tra il materiale rimosso e rigidità nella finitura.
Use the widest Insert and the largest Toolholder permissible, (for a better rate of material removal, better rigidity and surface finish)
- 1.2 Utilizzare l'utensile con una sporgenza più corta (T Max) per ottenere un miglior rapporto tra il materiale rimosso e rigidità nella finitura.
Use the shortest Grooving Tool overhang (T max), (for a better rate of material removal, better rigidity and surface finish)
- 1.3 Utilizzare l'utensile più largo con il diametro massimo in relazione al primo taglio di scanalatura. Se il diametro dell'incudine è troppo largo interferirà col diametro esterno; se è troppo piccolo interferirà col diametro interno.
Use the largest Grooving Tool with the maximum diameter in relation with the first grooving cut. If the Grooving Tool Anvil diameter is too large, will interferes with the outer Dia., if it is too small will interferes with the inner Dia.

2 Preparazione dell'utensile

Tool Set-Up

- 2.1 Utilizzare l'inserto più ampio e l'utensile più largo possibile per ottenere un miglior rapporto tra il materiale rimosso e rigidità nella finitura.
Use the widest Insert and the largest Toolholder permissible, (for a better rate of material removal, better rigidity and surface finish)

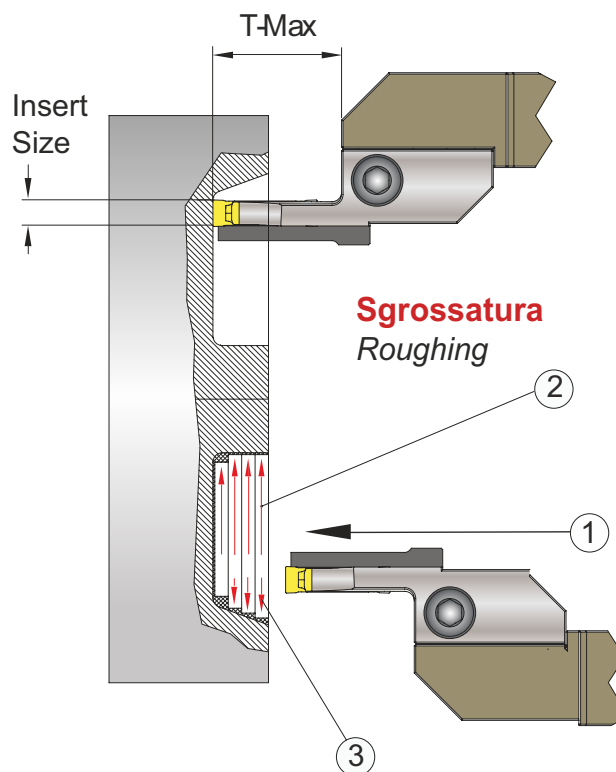

Lavorazioni / Operations

3 Sgrossatura

Roughing

- 3.1 Effettuare il primo taglio vicino al diametro esterno. La profondità del taglio deve essere la stessa nelle seguenti operazioni di tornitura.
Make the First Cut Diameter close to the outer Dia. the depth of cut to be the same of the following face turning operation
- 3.2 Scanalatura della stessa profondità di taglio della successiva tornitura.
Step groove the same depth of cut selected for the next face turning
- 3.3 Una volta raggiunta la profondità di scanalatura, tornire dal centro verso il diametro esterno.
Once reached the depth of the groove, face turn away from center close to the outer Dia.
- 3.4 Riportare l'inserto alla posizione iniziale, e tornire verso il centro vicino al diametro interno.
Bring the Insert to the initial position, and face turn toward the center close to the inner Dia.
- 3.5 Ripetere l'operazione finché la scanalatura approssimativa è completa e pronta per l'operazione di finitura.
Repeat the operation till the groove is complete roughed and ready for the finishing operation

4 Finitura

Finishing

- 4.1 Posizionare l'utensile vicino al diametro esterno.
Position the Grooving Tool close to the outer Dia.
- 4.2 Finire il diametro esterno alla profondità di scanalatura finale, continuare a tornire verso il centro senza toccare la parete.
Finish boring the outer Diameter to the final groove depth, continue face turning to the center without touching the wall
- 4.3 Rapido movimento dell'utensile sull'angolo del diametro interno, finire il diametro interno fino alla profondità di scanalatura finale.
Rapid move the Grooving Tool on the edge of the inner Diameter, Finish boring the inner Diameter to the final groove depth.

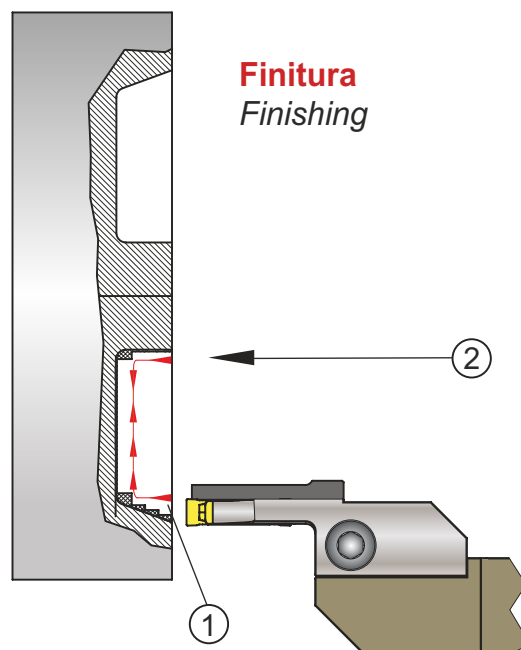

Uso corretto dell'utensile di Tornitura / Scanalatura Frontale

Modular Face Turning and Grooving working rotation

Utensile Modulare Sinistro "B"
Left Hand Modular Toolholder "B"

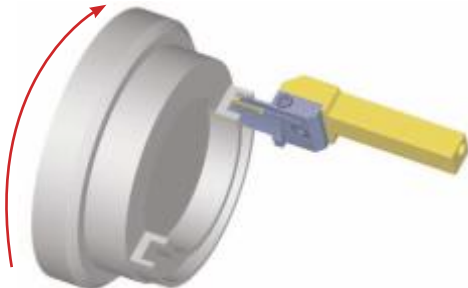

Utensile Modulare Perpendicolare Sinistro "B"
Left Hand Modular Perpendicular Toolholder "B"

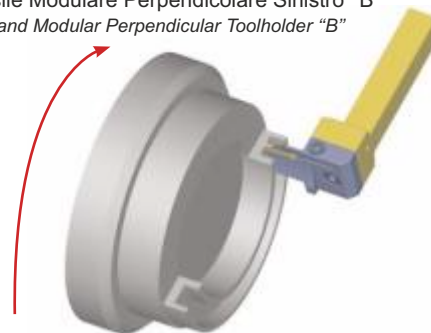

Rotazione Oraria
Clock wise rotation

Utensile Modulare Destro "A"
Right Hand Modular Toolholder "A"

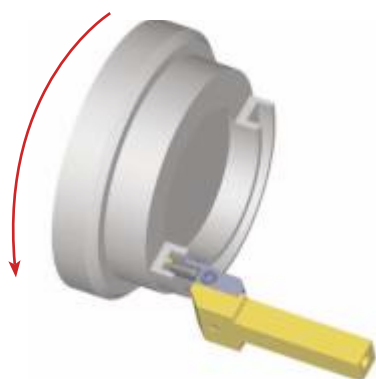

Utensile Modulare Perpendicolare Destro "A"
Right Hand Modular Perpendicular Toolholder "A"

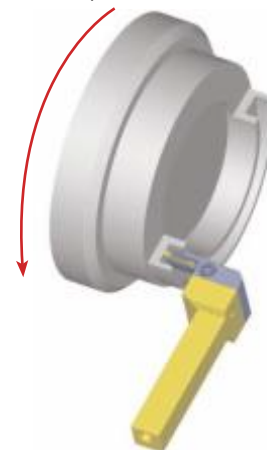

Rotazione Anti-Oraria
Counter clock wise rotation

Danno causato al Primo Taglio quando gli utensili sono scelti in maniera sbagliata
Damage caused at the First Cut when tools are chosen incorrectly

Utensile non corretto, Diametro troppo largo
Uncorrect Toolholder, Large Dia. Anvil

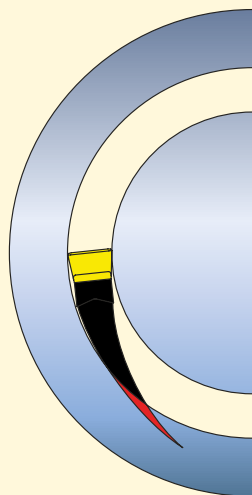

Utensile corretto, Diametro esatto
Correct Toolholder, Right Dia. Anvil

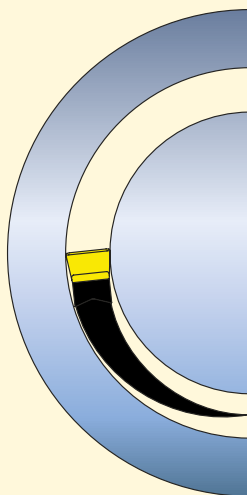

Utensile non corretto, Diametro troppo stretto
Uncorrect Toolholder, Small Dia. Anvil

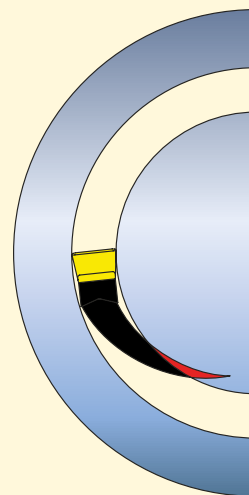

Azzeramento utensile

Azzerare l'utensile in modo che sia perpendicolare al pezzo da lavorare. Per una migliore performance in tornitura e scanalatura, l'utensile deve essere posizionato a $90^\circ \pm 10'$.

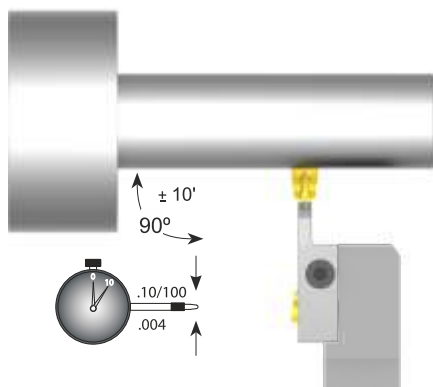

Tool Set-Up

Set the toolholder to be set-up square and perpendicular to the workpiece. For best turning and grooving performance, surface finish and a straight and square face, the toolholder must be positioned at 90° within $\pm 10'$

Altezza tagliente

Il tagliente dell'inserto non deve mai essere sotto la mezzeria del pezzo. Per evitare vibrazioni o scheggiature del tagliente è consigliabile posizionarlo (0.1 mm) sopra la mezzeria.

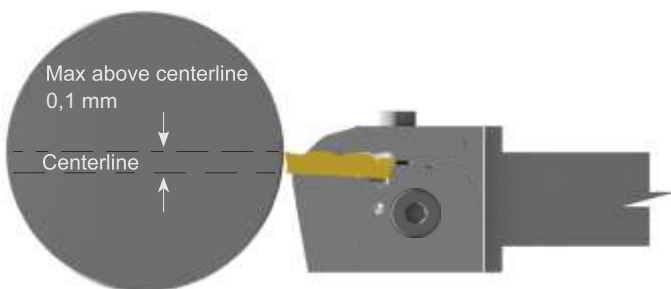

Tool Center Height

The cutting edge of the insert, should never be under the center line. The if the insert is under the center line, it will cause vibration and cutting edge chipping. For best results set the insert .004" (.1mm) above the center line.

Scelta utensile

Per un miglior risultato in tornitura e scanalatura, scegliere l'utensile con lo stelo più grande possibile. Per garantire una miglior finitura, tolleranze più strette e riduzione delle vibrazioni, è indispensabile una buona rigidità.



Shank Size

For best turning and grooving performance, select a toolholder with the largest shank permissible. With high rigidity, vibration are eliminate, with a better surface finish and close working tolerance.

Scelta delle profondità di taglio

In tornitura e scanalatura, la rigidità è fondamentale per ottenere le migliori prestazioni di taglio, buona finitura superficiale, strette tolleranze e allungare la durata dell' inserto. Nella scelta del portautensili, utilizzare sempre la "T" più corta possibile per evitare flessione durante la lavorazione.

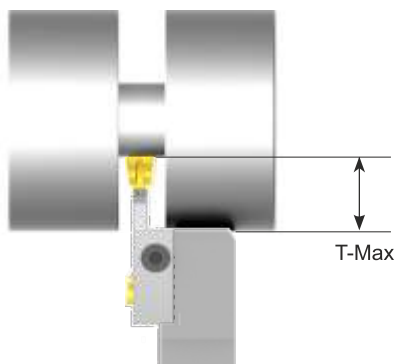

Extended "T" Depth of Cut

In Turning and grooving, rigidity it is critical to achieve best cutting performance, surface finish, close tolerance and insert life. In choosing the toolholder, always use the shortest "T" overhang possible, to avoid deflection under the cutting pressure.

Larghezza inserto

Per ottenere un miglior risultato, utilizzare l'inserto con maggior larghezza possibile, permettendo anche di ottenere una miglior finitura, maggior profondità di taglio e tolleranze più strette.

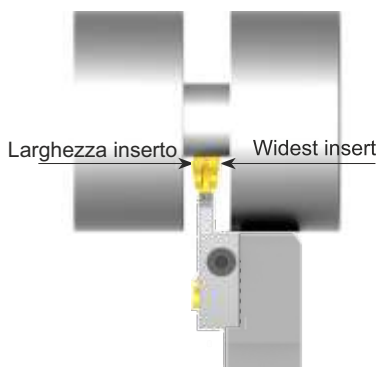

Insert Width

In turning and grooving operation: for maximize the performance choose the widest insert permissible. A wide insert, will not deflect under cutting pressure, allowing larger depth of cut, better surface finish and close tolerances.

Massima profondità di scanalatura - T-max

Nelle operazioni di scanalatura e troncatura, la profondità massima di scanalatura è direttamente correlata alla larghezza e la geometria l'inserto tagliente.
 T = max. profondità di troncatura diritta 8 x W (larghezza inserto)
 T = max. profondità di troncatura inclinata 6 x W (larghezza inserto).

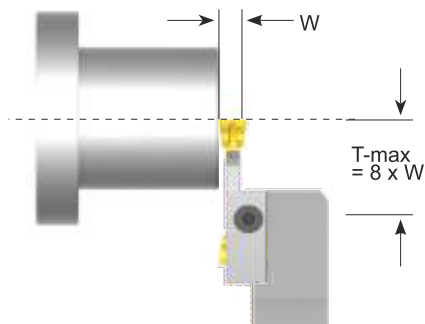

Max.Grooving Depth T-max

In Grooving and Parting-Off operation, for optimum results, the maximum grooving depth is directly related to the width and the geometry of the insert cutting edge.
 T= For Straight Insert Cutting Edge, 8 x W (insert width)
 T= For Angled Insert Cutting Edge, 6 x W (insert width)

Velocità di taglio - Vc

Per ottenere una buona finitura superficiale è necessario utilizzare una velocità di taglio costante ed aumentarla più ci si avvicina al centro del pezzo da troncatura.

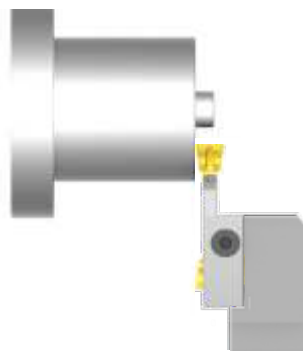

Cutting Speed Vc

For a good surface finish, straight face and long insert life, a constant Vc must be applied, meaning as the insert approaches the center of the work piece, RPM must increase.

Profondità di taglio/passata

Per ottenere buoni risultati durante la tornitura, un buon controllo del truciolo e una migliore durata dell'inserto, utilizzare l'utensile con la T=max più corta possibile e non superare mai la metà della larghezza dell'inserto per le profondità di taglio e/o passata.
 Esempio:
 5 mm larghezza inserto
 Max profondità di passata 2,5 mm
 La rottura dell'inserto potrebbe essere causata dalle vibrazioni dovute alla eccessiva lunghezza o sporgenza dell'utensile.

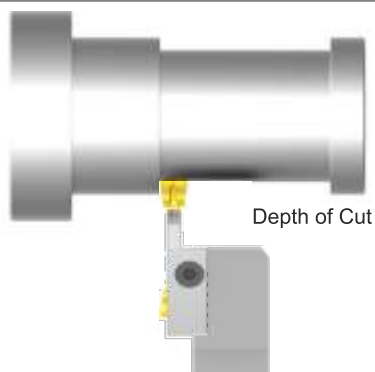

Depth of Cut

For best turning performance, chip control, and insert life under the best cutting condition with the shortest overhang, the depth of cut is not to exceed 50% of the width of the insert.
 For Example:
 5mm Insert
 Max Depth of Cut 2.5mm
 Reduce the depth of cut with extended overhang, vibration, insert chipping and toolholder breakage may result from an over extended overhang.

Avanzamento - fn

Per ottenere buoni risultati durante la tornitura, un buon controllo del truciolo e una migliore durata dell'inserto, utilizzare l'utensile con la T=max più corta possibile e la velocità dell'avanzamento non deve mai superare mai la metà della larghezza del raggio dell'inserto.
 Esempio:
 Raggio inserto 0,5
 Max. Avanzamento 0,25 mm
 La rottura dell'inserto potrebbe essere causata dalle vibrazioni dovute alla eccessiva velocità di avanzamento o dalla lunghezza o sporgenza dell'utensile.

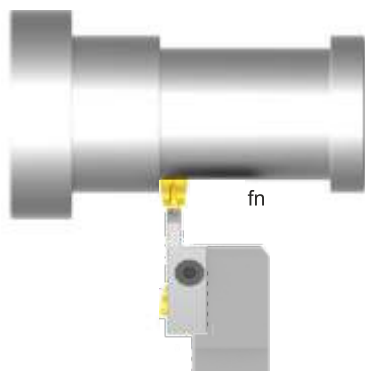

Feed Rate fn

For best turning performance, chip control, and insert life under the best cutting condition with the shortest overhang, the feed rate is not to exceed 1/2 of the insert radius.
 For Example:
 .5mm Insert Radius Max. Feed Rate of .25mm
 Reduce the feed rate, with extended overhang, vibration, insert chipping and toolholder breakage may result from an over extended overhang.

Wiper/Raschiante

Durante lo sforzo di taglio, l'inserto viene spinto via nella direzione opposta creando un angolo aperto. Questo angolo crea un'azione raschiante, con il risultato di ottenere una buona finitura superficiale. L'angolo Wiper/raschiante può essere controllato con avanzamento e la profondità di taglio.

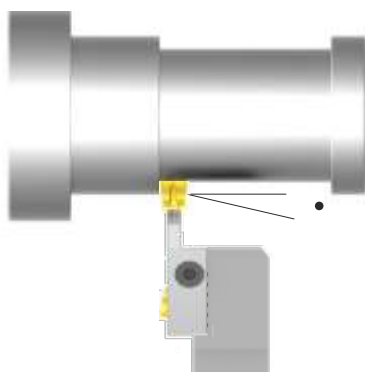

Wiper



Under cutting pressure, the insert is pushed away from the cutting direction creating an open space in form of relieve angle on trailing side of the insert. This angle creates a Wiper action, resulting a good surface finish. The Wiper angle can be controlled with feed rate and depth of cut.

Operazioni Multiple

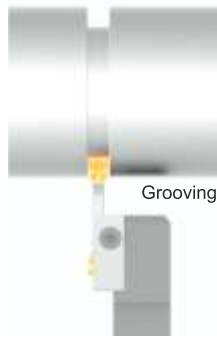

Grooving

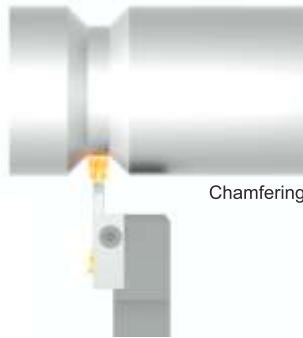

Chamfering

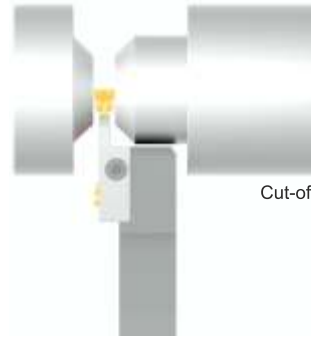

Cut-off

Multiple Operation

Troncatura diritta

In caso di troncatura diritta, utilizzare la miglior combinazione possibile tra inserto, velocità di taglio e di avanzamento. Tuttavia si rende necessaria una seconda operazione di finitura per rimuovere la parte centrale restante del pezzo troncato.

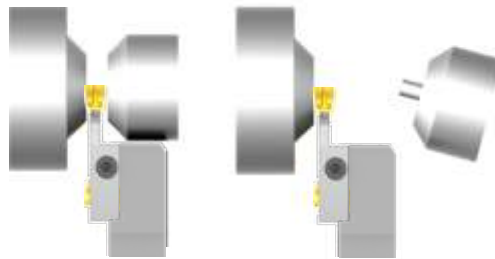

Straight Cutting Edge Insert

Use Turning and Grooving insert, with Straight Cutting Edge for fast material removal, good surface finish, deep grooving, parting-off and facing.

However, a second operation is required to remove the center tip of the workpiece when cut-off.

Troncatura inclinata

In caso di troncatura con inserto inclinato, questa permette di eliminare in un'unica operazione anche la parte centrale del pezzo troncato. Questo però è possibile riducendo del 20%-30% la V_c e F_n .

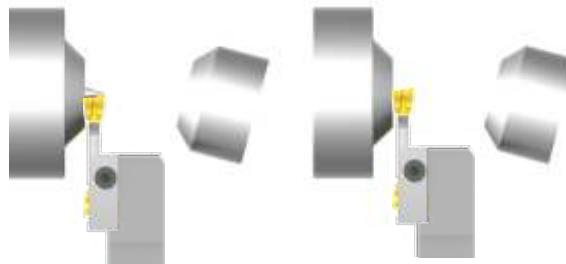

Angled Cutting Edge Face

Use Turning and Grooving insert, with Angled Cutting Edge to reduce the formation of center tip of workpiece when part-off eliminating the a secondary operations to remove the center tip.

However to avoid tapered face and rough surface finish V_c and f_n , as to be reduced 20% to 30% compared to full face insert.

Troncatura a tratti

Quando la troncatura supera 8 volte la larghezza dell'inserto è buona norma effettuare brevi soste, per permettere l'evacuazione del truciolo ed evitarne la rottura.

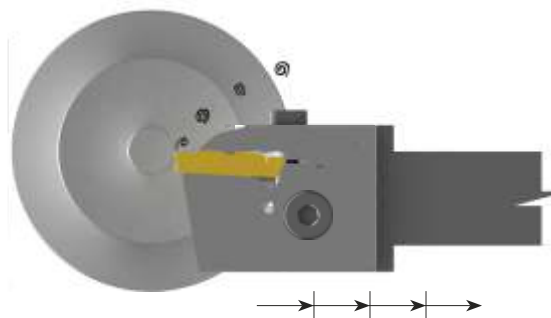

Pecking

When machining deep groove or parting large diameter above 8 time the width of the insert, it is a good practice to use pecking to achieve a better swarf control and avoid clogging of the groove, the major cause of premature insert failure.

Refrigerante

L'uso di refrigerante in tornitura e scanalatura è fondamentale per ottenere le migliori prestazioni di qualità, finitura superficiale e durata dell'inserto. Refrigerante ad alta pressione è consigliato, per raffreddare i trucioli e spingerli lontano dal tagliente, per evitare che eventuali trucioli rimangano all'interno del pezzo durante le operazioni di troncatura, evitando così la prematura rottura dell'inserto e una cattiva finitura superficiale.

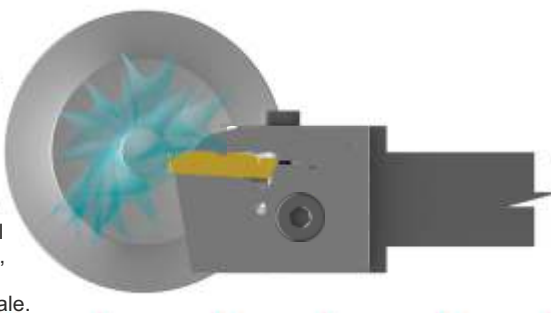

Coolant

The use of coolant in turning and grooving operations is critical to achieve best performance in quality, surface finish, and insert life. High pressure coolant is recommended, to cool the chips and force them to evacuate away from insert, to avoid any chip built-upon insert cutting edge, the cause of premature insert failure and rough surface finish.

Fase 1. Prima scanalatura

Azzerare il portautensili vicino al punto di partenza della scanalatura. Effettuare il primo taglio alla profondità del diametro di finito.



Step 1. First Groove

Set the toolholder close to starting point of the groove. Cut the first groove above the diameter finish dimension.

Fase 2. Scanalatura di sgrossatura

Ripetere l'operazione a distanze uguali, facendo in modo che lo spessore delle parti rimanenti sia del 20% in meno della larghezza dell'inserto usato per la lavorazione.

Esempio:
inserto 5 mm spessore pareti 4,0 mm

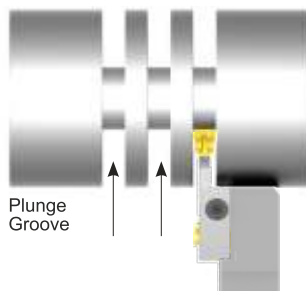

Step 2. Groove Roughing

Repeat the operation in equal segments for the total length to be turned. The wall of the segment should be the width of the insert less 20%.

For Example:
5 mm Insert Wall 4.0 mm width
.200" Insert Wall .180" width

Fase 3. Rimozione pareti

Eliminare le pareti rimanenti fino allo stesso diametro delle precedenti scanalature.

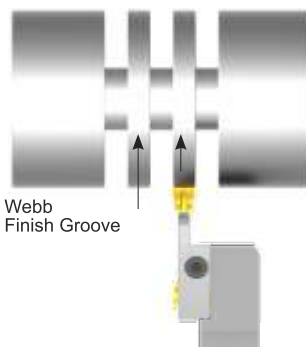

Step 3. Web Roughing

Cut the webs with the same diameter of the grooves.

Fase 4. Scanalatura di finitura

Effettuare la tornitura di finitura al diametro richiesto. Ritirare l'utensile uscendo a 45° del lato della parete.

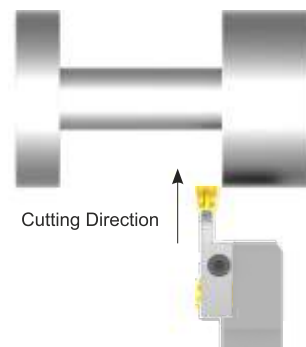

Step 4. First Finishing Cut

Face-off at finish dimension one side of the groove to the finished diameter, then retract the toolholder at 45° from the wall.

Fase 5. Finitura

Partire dal lato opposto alla precedente lavorazione. Iniziare asportando parte della parete fino al diametro finale ed uscire a 45° non intaccando il lato precedentemente lavorato.

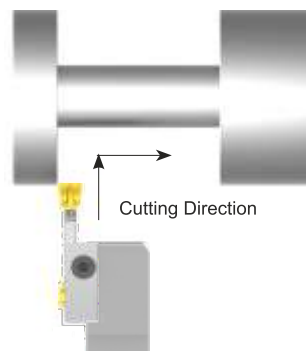

Step 5. Final Finishing Cut

Move the toolholder on the other side of the wall of the groove face-off to the finished diameter and continue to cut the entire surface till the other wall is reached, then retract the toolholder at 45° away from the wall.

**Fase 1.
Prima scanalatura**

Azzerare il portautensili vicino al punto di partenza della scanalatura. Effettuare il primo taglio alla profondità del diametro finito.

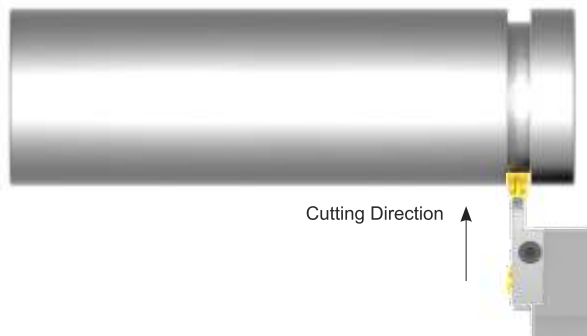

**Step 1.
Starting Groove**

Set the toolholder close to the starting point of the groove. Cut the first groove to depth of the first roughing cutting diameter.

**Fase 2.
Prima tornitura di sgrossatura**

Una volta fatta la prima profondità di scanalatura, effettuare la tornitura del pezzo fino alla lunghezza di tornitura richiesta. Ritrarre sempre l'utensile uscendo a 45° del pezzo da lavorare.

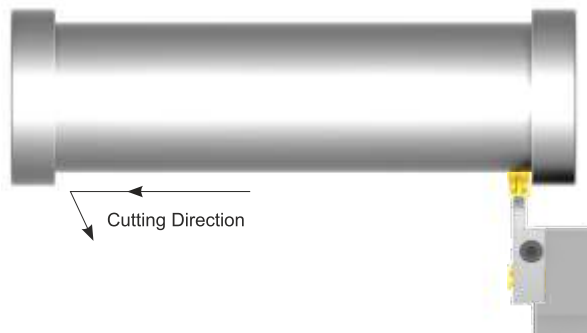

**Step 2.
First Turning Roughing Cut**

Once on the first groove is cut, feed the insert toward the other side of the workpiece. Cut till the end is reached then retract the toolholder at 45° away from the wall.

**Fase 3.
Tornitura multipla di sgrossatura**

Dopo il primo taglio di sgrossatura, ripetere l'operazione da un lato all'altro fino a quando la sgrossatura è completa.

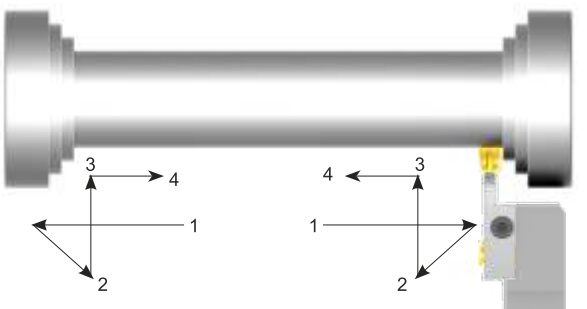

**Step 3.
Multi Turning Roughing Cut**

After the first roughing cut, repeat the operation from side to side until the roughing operation is complete.

**Fase 4.
Scanalatura di finitura**

Effettuare la tornitura di finitura al diametro richiesto. Ritrarre l'utensile uscendo a 45° del lato della parete.

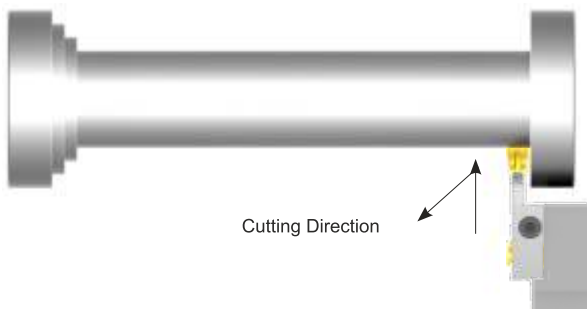

**Step 4.
First Finishing Cut**

Face-off at finish dimension one side of the groove to the finished diameter, then retract the toolholder at 45° away from the wall.

**Fase 4.
Finitura**

Partire dal lato opposto alla precedente lavorazione. Iniziare asportando parte della parete fino al diametro finale ed uscire a 45° non intaccando il lato precedentemente lavorato.

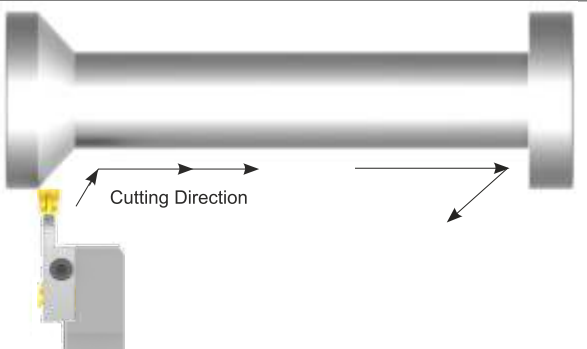

**Step 5.
Final Finishing Cut**

Move the toolholder on the other side of the wall of the groove face-off to the finished diameter and continue to cut the entire surface till the other wall is reached, then retract the toolholder at 45° away from the wall.

Guida alla scelta degli Utensili Modulari con attacco "Poligonale"

"Polygonal" Modular Tools Selection guide



Utensile Modulare Poligonale 90° tipo "A"
Modular Polygonal Toolholder 90° type "A"

CCGL...-A



CPML-C...-A



CCFR...-A

Utensile Modulare Poligonale Doppio 0° "AB"
Modular Polygonal Double Toolholder 0° "AB"



CHMN-C...-AB

Inserti = 2-3-4-5-6
Inserts = 2-3-4-5-6

Utensile Modulare Poligonale 90° tipo "B"
Modular Polygonal Toolholder 90° type "B"

CCGR...-B



CPMR-C...-B



CCFL...-B

Guida alla scelta degli Utensili Modulari con attacco "Standard"

"Standard" Modular Tools selection guide

Utensile Modulare 0° tipo "A"
Modular Toolholder 0° type "A"



CHML...-A

Inserti = 2-3-4-5-6
Inserts = 2-3-4-5-6

CCGL...-A



CCFR...-A

Utensile Modulare 90° tipo "A"
Modular Toolholder 90° type "A"

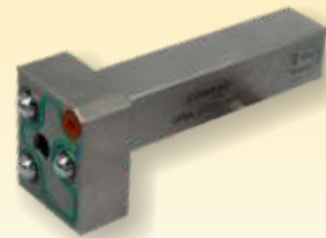

CPML...-A

Utensile Modulare 0° tipo "B"
Modular Toolholder 0° type "B"



CHMR...-B

Inserti = 2-3-4-5-6
Inserts = 2-3-4-5-6

CCGR...-B



CCFL...-B

Utensile Modulare 90° tipo "B"
Modular Toolholder 90° type "B"

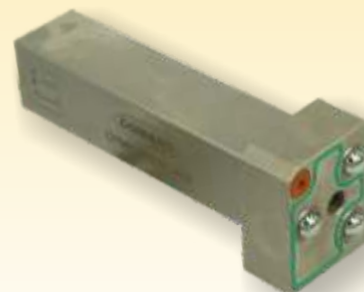



CPMR...-B

CHMN-C... NEW

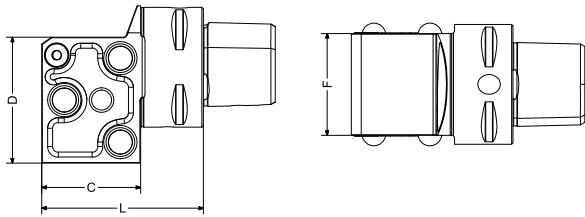
Utensili Modulari 0° con attacco Poligonale ISO 26623-1



Codice Code	Dimensioni / Dimensions					Cartuccia Cartridge	Parti di ricambio / Spare parts		
	Attacco / Shank Coupling	C	D	F	L				
CHMN-C04-AB	C04	33	42	34	54	CCGL...-A	VB08..	CSC83	CBR60
CHMN-C05-AB	C05	33	42	37	54	CCFR...-A	VB08..	CSC83	CBR60
CHMN-C06-AB	C06	33	42	49	56	CCGR...-B CCFL...-B	VB08..	CSC83	CBR60

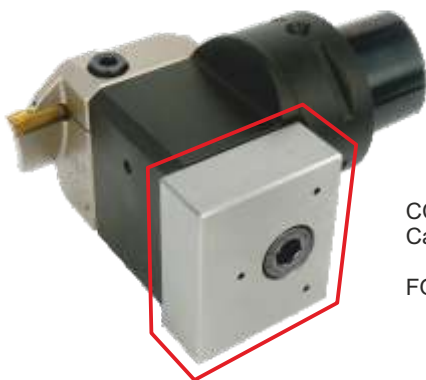

CCPN-00
 Cartuccia-Tappo / Cartridge-Plug
 FORNITA IN DOTAZIONE / SUPPLIED

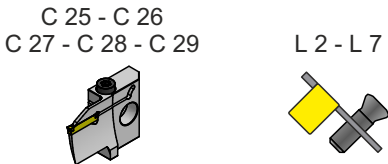

CPML-C...-A NEW

Modular Polygonal Toolholders 90° ISO 26623-1 type "A"
 Porte-outils Polygonaux Modulaires 90° ISO 26623-1 type "A"
 Modulare Polygonhalter 90° ISO 26623-1 "A"
 Utensilios Modulares Poligonales 90° ISO 26623-1 tipos "A"

Utensili Modulari 90° con attacco Poligonale ISO 26623-1 Tipo "A"

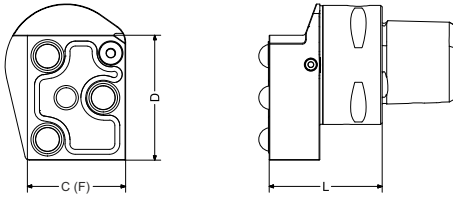

Codice Code	Dimensioni / Dimensions					Cartuccia Cartridge	Parti di ricambio / Spare parts		
	Attacco / Shank Coupling	C	D	F	L				
CPML-C04-A	C04	33	42	33	38	CCFR...-A CCGL...-A	VB08..	CSC83	CBR60
CPML-C05-A	C05	33	42	33	38		VB08..	CSC83	CBR60
CPML-C06-A	C06	33	42	33	40		VB08..	CSC83	CBR60

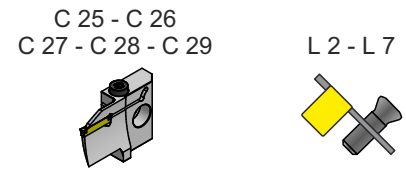

CPMR-C...-B



Modular Polygonal Toolholders 90° ISO 26623-1 type "B"
 Porte-outils Polygonaux Modulaires 90° ISO 26623-1 type "B"
 Modulare Polygonhalter 90° ISO 26623-1 "B"
 Utensilios Modulares Poligonales 90° ISO 26623-1 tipos "B"

Utensili Modulari 90° con attacco Poligonale ISO 26623-1 Tipo "B"

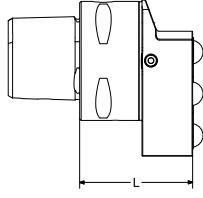
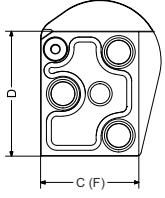

Codice Code	Dimensioni / Dimensions					Cartuccia Cartridge	Parti di ricambio / Spare parts		
	Attacco / Shank Coupling	C	D	F	L				
CPMR-C04-B	C04	33	42	33	38	CCFL...-B	VB08..	CSC83	CBR60
CPMR-C05-B	C05	33	42	33	38	CCGR...-B	VB08..	CSC83	CBR60
CPMR-C06-B	C06	33	42	33	40		VB08..	CSC83	CBR60

C 25 - C 26
 C 27 - C 28 - C 29

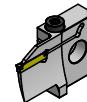

L 2 - L 7



CHML...34-A

Toolholders with cartridges for 0° face grooving
 Outil avec cartouche pour rainurage frontal a 0°
 Klemmhalter mit kassetten zum 0° Planstechen
 Utensilios con cartucha para ranura frontal a 0°

Utensili Modulari 0° tipo "A" con cartucce per scanalatura

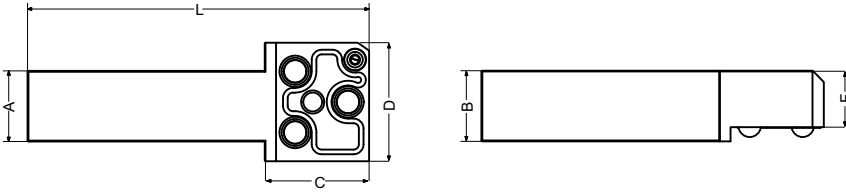

Codice Code	Dimensioni / Dimensions							Cartuccia Cartridge	Parti di ricambio / Spare parts		
	A	B	C	D	F	L					
CHML 2020K 34-A	20	20	37	42	15	106	CCFR...-A CCGL...-A	VB0820	CSC83	CBR60	
CHML 2525M 34-A	25	25	37	42	20	121		VB0820	CSC83	CBR60	
CHML 3225P 34-A	32	25	37	42	20	136		VB0820	CSC83	CBR60	



C 25 - C 26
 C 27 - C 28 - C 29

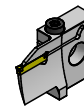

CPML...34-A

Toolholders with cartridges for 90° face grooving
 Outil avec cartouche pour rainurage frontal a 90°
 Klemmhalter mit kassetten zum 90° Planstechen
 Utensilios con cartucha para ranura frontal a 90°

Utensili Modulari 90° tipo "A" con cartucce per scanalatura

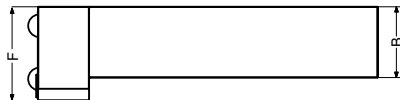
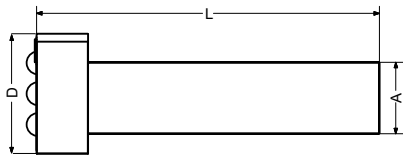
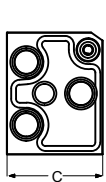

Codice Code	Dimensioni / Dimensions							Cartuccia Cartridge	Parti di ricambio / Spare parts		
	A	B	C	D	F	L					
CPML 2020K 34-A	20	20	33	42	33	111	CCFR...-A CCGL...-A	VB0820	CSC83	CBR60	
CPML 2525M 34-A	25	25	33	42	33	120		VB0820	CSC83	CBR60	
CPML 3232P 34-A	32	32	33	42	33	130		VB0820	CSC83	CBR60	

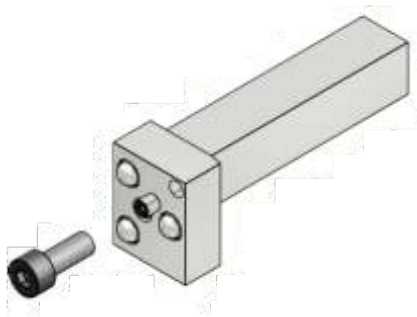

C 25 - C 26
C 27 - C 28 - C 29

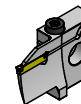

L 2 - L 7





CCGL...20/30/40/50/60-A

Cartridges for radial grooving
 Cartouche pour rainurage radial
 Kassetten zum radialschlitz
 Cartuchas para ranura radial

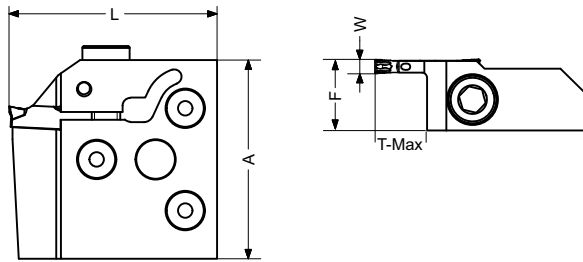
Cartucce per scanalatura radiale con inserto 2 / 3 / 4 / 5 / 6 mm



Codice Code	Dimensioni / Dimensions					Inserto Insert	Parti di ricambio / Spare parts	
	T max	L	A	F	W			
CCGL 20 09-A	09	43	42	14	2.0	CTSN 22-20	VB0624	CBR40
CCGL 20 18-A	18	52	42	14	2.0	CTSN 22-20	VB0624	CBR40
CCGL 30 10-A	10	44	42	14,5	3.0	CTSN 22-30..	VB0624	CBR40
CCGL 30 20-A	20	54	42	14,5	3.0	CTSN 22-30..	VB0624	CBR40
CCGL 40 12-A	12	46	42	15	4.0	CTSN 25-40..	VB0624	CBR40
CCGL 40 24-A	24	58	42	15	4.0	CTSN 25-40..	VB0624	CBR40
CCGL 50 15-A	15	50	42	15,5	5.0	CTSN 25-50..	VB0624	CBR40
CCGL 50 30-A	30	65	42	15,5	5.0	CTSN 25-50..	VB0624	CBR40
CCGL 60 20-A	20	55	42	16	6.0	CTSN 25-60..	VB0624	CBR40
CCGL 60 40-A	40	75	42	16	6.0	CTSN 25-60..	VB0624	CBR40

Tipo di lavorazione - Machining Types

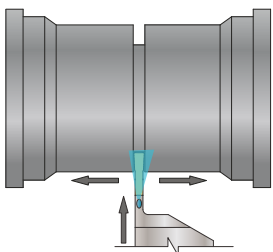

C x 5



L 2 - L 7





CCFR...30-A

Cartridges for face grooving
 Cartouche pour rainurage frontal
 Kassetten zum planstechen
 Cartuchas para ranura frontal

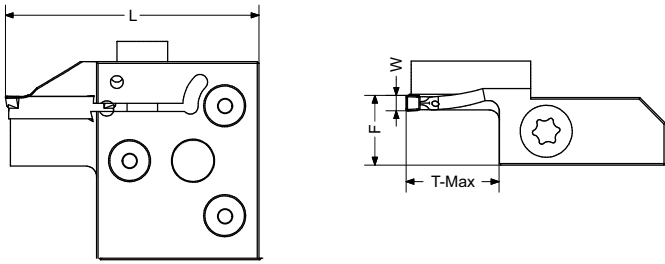
Cartucce per scanalatura frontale con inserto 3 mm



Codice Code	Dimensioni / Dimensions						Inserto Insert	Parti di ricambio / Spare parts	
	D min.	D max.	T max	L	W	F			
Prof. taglio 10 mm / Depth of Cut 10 mm									
CCFR 2230 30 10-A	22	36	10	45	3.0	14	CTSN 22-30..	VB0518	CBR40
CCFR 3038 30 10-A	30	44	10	45	3.0	14	CTSN 22-30..	VB0518	CBR40
CCFR 3848 30 10-A	38	54	10	45	3.0	14	CTSN 22-30..	VB0518	CBR40
CCFR 4860 30 10-A	48	66	10	45	3.0	14	CTSN 22-30..	VB0518	CBR40
CCFR 6075 30 10-A	60	81	10	45	3.0	14	CTSN 22-30..	VB0518	CBR40
CCFR 75100 30 10-A	75	106	10	45	3.0	14	CTSN 22-30..	VB0518	CBR40
CCFR 100200 30 10-A	100	206	10	45	3.0	14	CTSN 22-30..	VB0518	CBR40
CCFR 200-> 30 10-A	200	>206	10	45	3.0	14	CTSN 22-30..	VB0518	CBR40
Prof. taglio 20 mm / Depth of Cut 20 mm									
CCFR 6075 30 20-A	60	81	20	55	3.0	14	CTSN 22-30..	VB0518	CBR40
CCFR 75100 30 20-A	75	106	20	55	3.0	14	CTSN 22-30..	VB0518	CBR40
CCFR 100200 30 20-A	100	206	20	55	3.0	14	CTSN 22-30..	VB0518	CBR40
CCFR 200-> 30 20-A	200	>206	20	55	3.0	14	CTSN 22-30..	VB0518	CBR40

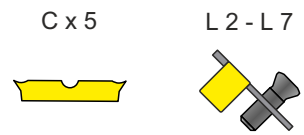
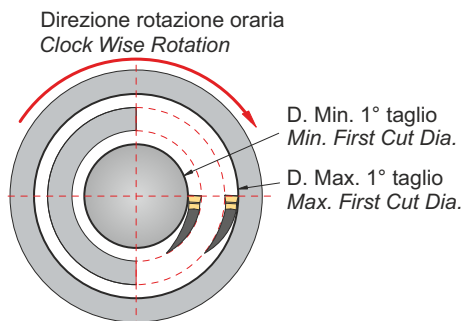

CCFR...40-A

Cartridges for face grooving
 Cartouche pour rainurage frontal
 Kassetten zum planstechen
 Cartuchas para ranura frontal

Cartucce per scanalatura frontale con inserto 4 mm

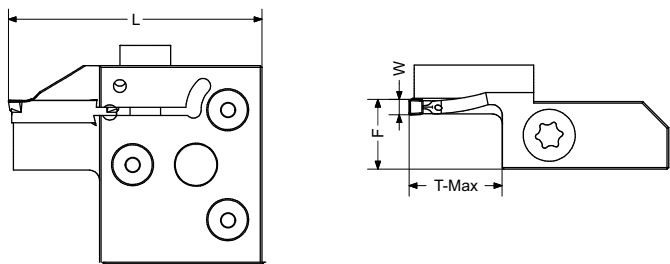

Codice Code	Dimensioni / Dimensions						Inserto Insert	Parti di ricambio / Spare parts	
	D min.	D max.	T max	L	W	F			
Prof. taglio 12 mm / Depth of Cut 12 mm									
CCFR 3048 40 12-A	30	56	12	54	4.0	14,5	CTSN 25-40..	VB0518	CBR40
CCFR 4860 40 12-A	48	68	12	54	4.0	14,5	CTSN 25-40..	VB0518	CBR40
CCFR 6075 40 12-A	60	83	12	54	4.0	14,5	CTSN 25-40..	VB0518	CBR40
CCFR 75100 40 12-A	75	108	12	54	4.0	14,5	CTSN 25-40..	VB0518	CBR40
CCFR 100150 40 12-A	100	158	12	54	4.0	14,5	CTSN 25-40..	VB0518	CBR40
CCFR 150-> 40 12-A	150	>158	12	54	4.0	14,5	CTSN 25-40..	VB0518	CBR40
Prof. taglio 24 mm / Depth of Cut 24 mm									
CCFR 3048 40 24-A	30	56	24	60	4.0	14,5	CTSN 25-40..	VB0518	CBR40
CCFR 4860 40 24-A	48	68	24	60	4.0	14,5	CTSN 25-40..	VB0518	CBR40
CCFR 6075 40 24-A	60	83	24	60	4.0	14,5	CTSN 25-40..	VB0518	CBR40
CCFR 75100 40 24-A	75	108	24	60	4.0	14,5	CTSN 25-40..	VB0518	CBR40
CCFR 100150 40 24-A	100	158	24	60	4.0	14,5	CTSN 25-40..	VB0518	CBR40
CCFR 150-> 40 24-A	150	>158	24	60	4.0	14,5	CTSN 25-40..	VB0518	CBR40

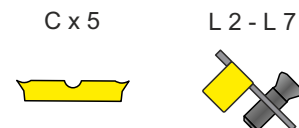
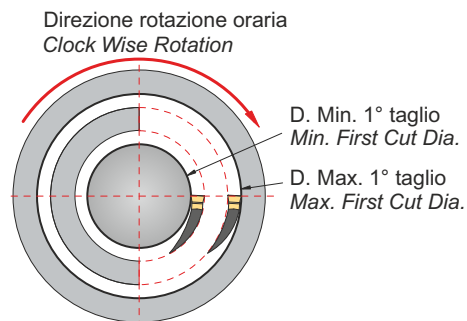



CCFR...50-A

Cartridges for face grooving
 Cartouche pour rainurage frontal
 Kassetten zum planstechen
 Cartuchas para ranura frontal

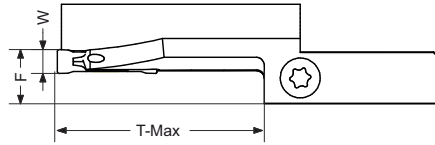
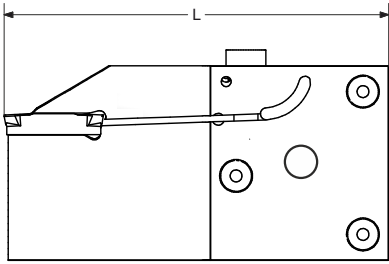
Cartucce per scanalatura frontale con inserto 5 mm



Codice Code	Dimensioni / Dimensions						Inserto Insert	Parti di ricambio / Spare parts	
	D min.	D max.	T max	L	W	F			
Prof. taglio 22 mm / Depth of Cut 22 mm									
CCFR 4255 50 22-A	42	55	22	60	5.0	14	CTSN 25-50..	VB0518	CBR40
CCFR 5575 50 22-A	55	85	22	60	5.0	14	CTSN 25-50..	VB0518	CBR40
CCFR 75130 50 22-A	75	140	22	60	5.0	14	CTSN 25-50..	VB0518	CBR40
CCFR 130200 50 22-A	130	210	22	60	5.0	14	CTSN 25-50..	VB0518	CBR40
CCFR 200-> 50 22-A	200	>210	22	60	5.0	14	CTSN 25-50..	VB0518	CBR40
Prof. taglio 45 mm / Depth of Cut 45 mm									
CCFR 130200 50 45-A	130	210	45	92	5.0	14	CTSN 25-50..	VB0518	CBR40
CCFR 200450 50 45-A	200	460	45	92	5.0	14	CTSN 25-50..	VB0518	CBR40
CCFR 450-> 50 45-A	450	>460	45	92	5.0	14	CTSN 25-50..	VB0518	CBR40

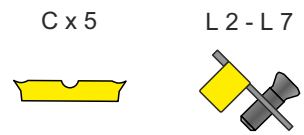
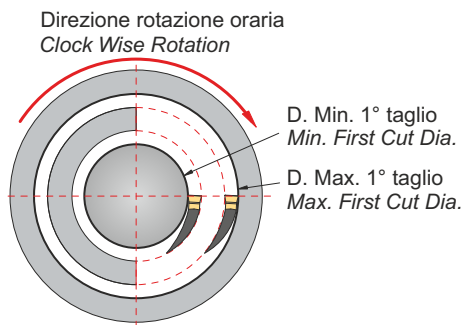

CCFR...60-A

Cartridges for face grooving
 Cartouche pour rainurage frontal
 Kassetten zum planstechen
 Cartuchas para ranura frontal

Cartucce per scanalatura frontale con inserto 6 mm

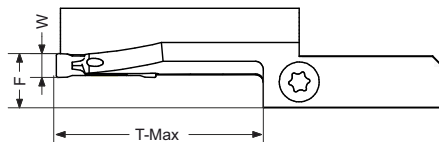
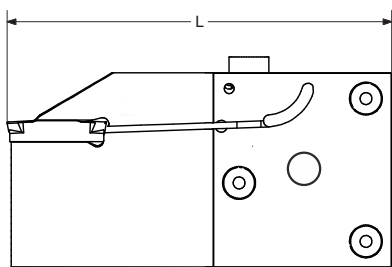

Codice Code	Dimensioni / Dimensions						Inserto Insert	Parti di ricambio / Spare parts	
	D min.	D max.	T max	L	W	F			
Prof. taglio 22 mm / Depth of Cut 22 mm									
CCFR 4255 60 22-A	42	67	22	60	6.0	14	CTSN 25-60..	VB0518	CBR40
CCFR 5575 60 22-A	55	87	22	60	6.0	14	CTSN 25-60..	VB0518	CBR40
CCFR 75130 60 22-A	75	142	22	60	6.0	14	CTSN 25-60..	VB0518	CBR40
CCFR 130200 60 22-A	130	212	22	60	6.0	14	CTSN 25-60..	VB0518	CBR40
CCFR 200-> 60 22-A	200	>212	22	60	6.0	14	CTSN 25-60..	VB0518	CBR40
Prof. taglio 45 mm / Depth of Cut 45 mm									
CCFR 130200 60 45-A	130	212	45	92	6.0	14	CTSN 25-60..	VB0518	CBR40
CCFR 200450 60 45-A	200	462	45	92	6.0	14	CTSN 25-60..	VB0518	CBR40
CCFR 450-> 60 45-A	450	>462	45	92	6.0	14	CTSN 25-60..	VB0518	CBR40

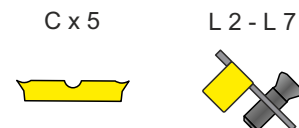
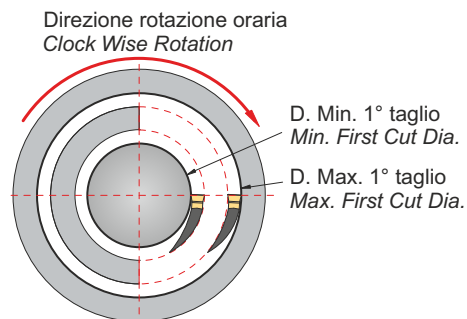



CHMR...34-B

Toolholders with cartridges for face grooving
 Outil avec cartouche pour rainurage frontal
 Klemmhalter mit kassetten zum Planstechen
 Utensilios con cartucha para ranura frontal

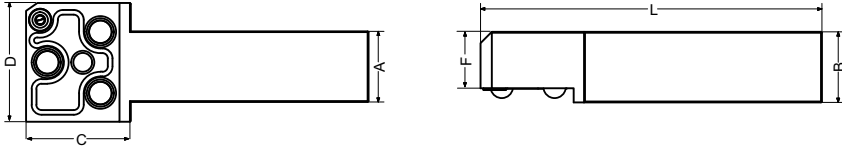
Utensili Modulari 0° tipo "B" con cartucce per scanalatura



Codice Code	Dimensioni / Dimensions							Cartuccia Cartridge	Parti di ricambio / Spare parts		
	A	B	C	D	F	L					
CHMR 2020K 34-B	20	20	37	42	15	106	CCFL...-B CCGR...-B	VB0820	CSC83	CBR60	
CHMR 2525M 34-B	25	25	37	42	20	121		VB0820	CSC83	CBR60	
CHMR 3225P 34-B	32	25	37	42	20	136		VB0820	CSC83	CBR60	

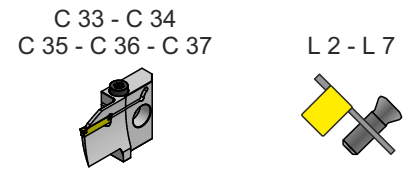

CPMR...34-B

Toolholders with cartridges for 90° face grooving
 Outil avec cartouche pour rainurage frontal a 90°
 Klemmhalter mit kassetten zum 90° Planstechen
 Utensilios con cartucha para ranura frontal a 90°

Utensili Modulari 90° tipo "B" con cartucce per scanalatura

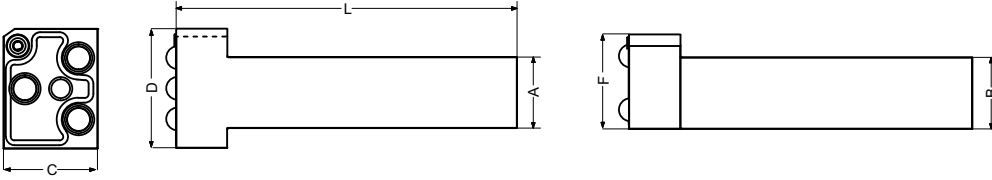

Codice Code	Dimensioni / Dimensions							Cartuccia Cartridge	Parti di ricambio / Spare parts		
	A	B	C	D	F	L					
CPMR 2020K 34-B	20	20	33	42	33	111	CCFL...-B CCGR...-B	VB0820	CSC83	CBR60	
CPMR 2525M 34-B	25	25	33	42	33	120		VB0820	CSC83	CBR60	
CPMR 3232P 34-B	32	32	33	42	33	130		VB0820	CSC83	CBR60	

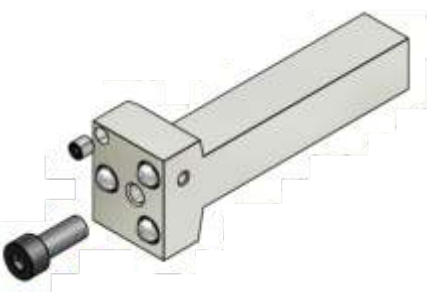

C 33 - C 34
 C 35 - C 36 - C 37



L 2 - L 7

CCGR...20/30/40/50/60-B

Cartridges for radial grooving
 Cartouche pour rainurage radial
 Kassetten zum radialschlitz
 Cartuchas para ranura radial

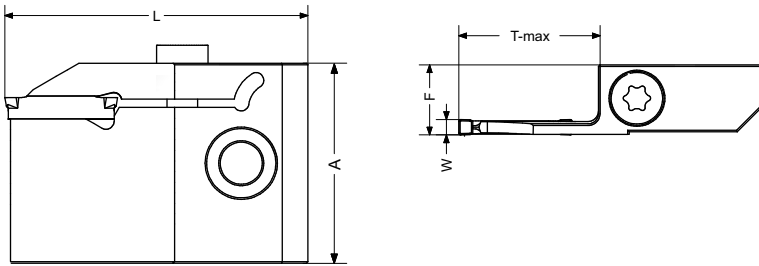
Cartucce per scanalatura radiale con inserto 2 / 3 / 4 / 5 / 6 mm



Codice Code	Dimensioni / Dimensions					Inserto Insert	Parti di ricambio / Spare parts	
	T max	L	A	F	W			
CCGR 20 09-B	09	43	42	14	2.0	CTSN 22-20	VB0624	CBR40
CCGR 20 18-B	18	52	42	14	2.0	CTSN 22-20	VB0624	CBR40
CCGR 30 10-B	10	44	42	15	3.0	CTSN 22-30..	VB0624	CBR40
CCGR 30 20-B	20	54	42	15	3.0	CTSN 22-30..	VB0624	CBR40
CCGR 40 12-B	12	46	42	14,5	4.0	CTSN 25-40..	VB0624	CBR40
CCGR 40 24-B	24	58	42	14,5	4.0	CTSN 25-40..	VB0624	CBR40
CCGR 50 15-B	15	50	42	15,5	5.0	CTSN 25-50..	VB0624	CBR40
CCGR 50 30-B	30	65	42	15,5	5.0	CTSN 25-50..	VB0624	CBR40
CCGR 60 20-B	20	55	42	16	6.0	CTSN 25-60..	VB0624	CBR40
CCGR 60 40-B	40	75	42	16	6.0	CTSN 25-60..	VB0624	CBR40

Tipo di lavorazione - Machining Types

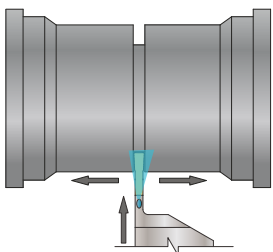

C x 5



L 2 - L 7



CCFL...30-B

Cartridges for face grooving
 Cartouche pour rainurage frontal
 Kassetten zum planstechen
 Cartuchas para ranura frontal

Cartucce per scanalatura frontale con inserto 3 mm

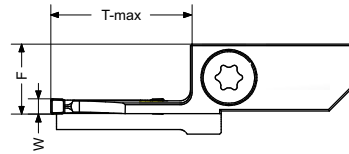
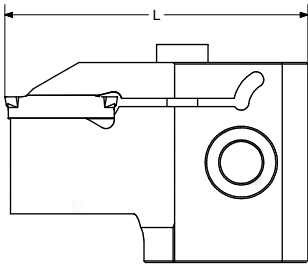

Codice Code	Dimensioni / Dimensions						Inserto Insert	Parti di ricambio / Spare parts	
	D min.	D max.	T max	L	W	F			
Prof. taglio 10 mm / Depth of Cut 10 mm									
CCFL 2230 30 10-B	22	36	10	50	3.0	14	CTSN 22-30..	VB0518	CBR40
CCFL 3038 30 10-B	30	44	10	50	3.0	14	CTSN 22-30..	VB0518	CBR40
CCFL 3848 30 10-B	38	54	10	50	3.0	14	CTSN 22-30..	VB0518	CBR40
CCFL 4860 30 10-B	48	66	10	50	3.0	14	CTSN 22-30..	VB0518	CBR40
CCFL 6075 30 10-B	60	81	10	50	3.0	14	CTSN 22-30..	VB0518	CBR40
CCFL 75100 30 10-B	75	106	10	50	3.0	14	CTSN 22-30..	VB0518	CBR40
CCFL 100200 30 10-B	100	206	10	50	3.0	14	CTSN 22-30..	VB0518	CBR40
CCFL 200-> 30 10-B	200	>206	10	50	3.0	14	CTSN 22-30..	VB0518	CBR40
Prof. taglio 20 mm / Depth of Cut 20 mm									
CCFL 6075 30 20-B	60	81	20	60	3.0	14	CTSN 22-30..	VB0518	CBR40
CCFL 75100 30 20-B	75	106	20	60	3.0	14	CTSN 22-30..	VB0518	CBR40
CCFL 100200 30 20-B	100	206	20	60	3.0	14	CTSN 22-30..	VB0518	CBR40
CCFL 200-> 30 20-B	200	>206	20	60	3.0	14	CTSN 22-30..	VB0518	CBR40

Direzione di rotazione antioraria
 Counter Clock Wise Rotation

D. Min. 1° taglio
 Min. First Cut Dia.

D. Max. 1° taglio
 Max. First Cut Dia.

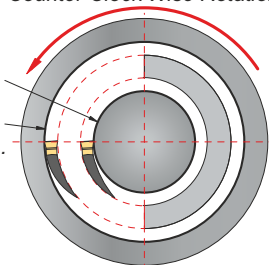

C x 5



L 2 - L 7





CCFL...40-B

Cartridges for face grooving
 Cartouche pour rainurage frontal
 Kassetten zum planstechen
 Cartuchas para ranura frontal

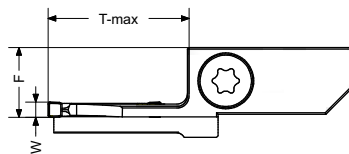
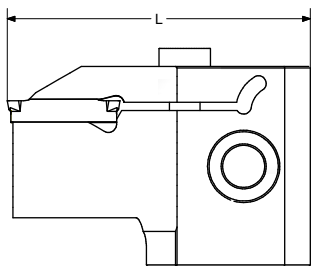
Cartucce per scanalatura frontale con inserto 4 mm



Codice Code	Dimensioni / Dimensions						Inserto Insert	Parti di ricambio / Spare parts	
	D min.	D max.	T max	L	W	F			
Prof. taglio 12 mm / Depth of Cut 12 mm									
CCFL 3048 40 12-B	30	56	12	54	4.0	14,5	CTSN 25-40..	VB0518	CBR40
CCFL 4860 40 12-B	48	68	12	54	4.0	14,5	CTSN 25-40..	VB0518	CBR40
CCFL 6075 40 12-B	60	83	12	54	4.0	14,5	CTSN 25-40..	VB0518	CBR40
CCFL 75100 40 12-B	75	108	12	54	4.0	14,5	CTSN 25-40..	VB0518	CBR40
CCFL 100150 40 12-B	100	158	12	54	4.0	14,5	CTSN 25-40..	VB0518	CBR40
CCFL 150-> 40 12-B	150	>158	12	54	4.0	14,5	CTSN 25-40..	VB0518	CBR40
Prof. taglio 24 mm / Depth of Cut 24 mm									
CCFL 3048 40 24-B	30	56	24	60	4.0	14,5	CTSN 25-40..	VB0518	CBR40
CCFL 4860 40 24-B	48	68	24	60	4.0	14,5	CTSN 25-40..	VB0518	CBR40
CCFL 6075 40 24-B	60	83	24	60	4.0	14,5	CTSN 25-40..	VB0518	CBR40
CCFL 75100 40 24-B	75	108	24	60	4.0	14,5	CTSN 25-40..	VB0518	CBR40
CCFL 100150 40 24-B	100	158	24	60	4.0	14,5	CTSN 25-40..	VB0518	CBR40
CCFL 150-> 40 24-B	150	>158	24	60	4.0	14,5	CTSN 25-40..	VB0518	CBR40

Direzione di rotazione antioraria
 Counter Clock Wise Rotation

D. Min. 1° taglio
 Min. First Cut Dia.
 D. Max. 1° taglio
 Max. First Cut Dia.

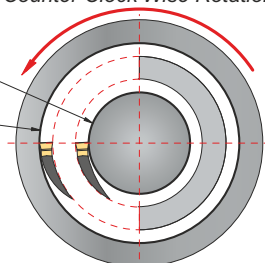

C x 5

L 2 - L 7





CCFL...50-B

Cartridges for face grooving
 Cartouche pour rainurage frontal
 Kassetten zum planstechen
 Cartuchas para ranura frontal

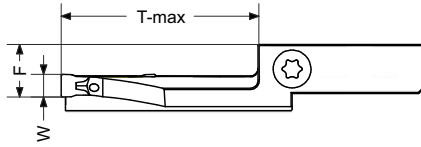
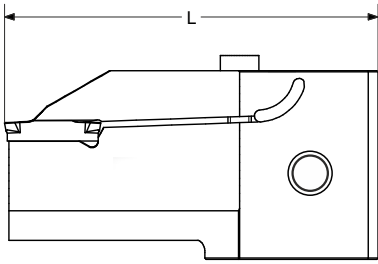
Cartucce per scanalatura frontale con inserto 5 mm



Codice Code	Dimensioni / Dimensions						Inserto Insert	Parti di ricambio / Spare parts	
	D min.	D max.	T max	L	W	F			
Prof. taglio 22 mm / Depth of Cut 22 mm									
CCFL 4255 50 22-B	42	55	22	60	5.0	14	CTSN 25-50..	VB0518	CBR40
CCFL 5575 50 22-B	55	85	22	60	5.0	14	CTSN 25-50..	VB0518	CBR40
CCFL 75130 50 22-B	75	140	22	60	5.0	14	CTSN 25-50..	VB0518	CBR40
CCFL 130200 50 22-B	130	210	22	60	5.0	14	CTSN 25-50..	VB0518	CBR40
CCFL 200-> 50 22-B	200	>210	22	60	5.0	14	CTSN 25-50..	VB0518	CBR40
Prof. taglio 45 mm / Depth of Cut 45 mm									
CCFL 130200 50 45-B	130	210	45	92	5.0	14	CTSN 25-50..	VB0518	CBR40
CCFL 200450 50 45-B	200	460	45	92	5.0	14	CTSN 25-50..	VB0518	CBR40
CCFL 450-> 50 45-B	450	>460	45	92	5.0	14	CTSN 25-50..	VB0518	CBR40

Direzione di rotazione antioraria
 Counter Clock Wise Rotation

D. Min. 1° taglio
 Min. First Cut Dia.

D. Max. 1° taglio
 Max. First Cut Dia.

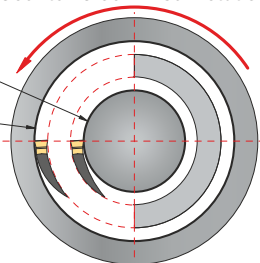

C x 5

L 2 - L 7



CCFL...60-B

Cartridges for face grooving
 Cartouche pour rainurage frontal
 Kassetten zum planstechen
 Cartuchas para ranura frontal

Cartucce per scanalatura frontale con inserto 6 mm

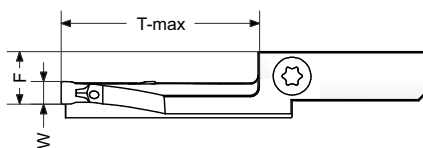
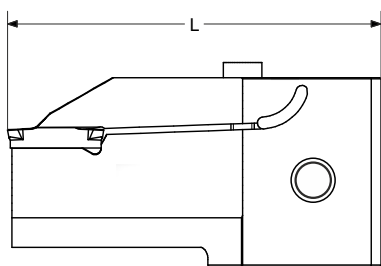

Codice Code	Dimensioni / Dimensions						Inserto Insert	Parti di ricambio / Spare parts	
	D min.	D max.	T max	L	W	F			
Prof. taglio 22 mm / Depth of Cut 22 mm									
CCFL 4255 60 22-B	42	67	22	60	6.0	14	CTSN 25-60..	VB0518	CBR40
CCFL 5575 60 22-B	55	87	22	60	6.0	14	CTSN 25-60..	VB0518	CBR40
CCFL 75130 60 22-B	75	142	22	60	6.0	14	CTSN 25-60..	VB0518	CBR40
CCFL 130200 60 22-B	130	212	22	60	6.0	14	CTSN 25-60..	VB0518	CBR40
CCFL 200-> 60 22-B	200	>212	22	60	6.0	14	CTSN 25-60..	VB0518	CBR40
Prof. taglio 45 mm / Depth of Cut 45 mm									
CCFL 130200 60 45-B	130	212	45	92	6.0	14	CTSN 25-60..	VB0518	CBR40
CCFL 200450 60 45-B	200	462	45	92	6.0	14	CTSN 25-60..	VB0518	CBR40
CCFL 450-> 60 45-B	450	>462	45	92	6.0	14	CTSN 25-60..	VB0518	CBR40

Direzione di rotazione antioraria
 Counter Clock Wise Rotation

D. Min. 1° taglio
 Min. First Cut Dia.
 D. Max. 1° taglio
 Max. First Cut Dia.

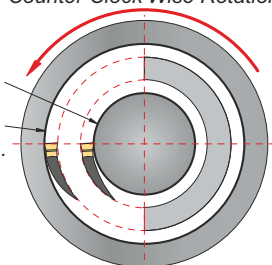

C x 5



L 2 - L 7



Accessori per l'Alta Pressione

Tubi - Raccordi - Tappi

Tubi per l'Alta Pressione / High Pressure Tubing	Codice / Code	Descrizione / Description
	HPT20-6	Tubo Alta Pressione / High Pressure Tubing - 200 mm
	HPT25-6	Tubo Alta Pressione / High Pressure Tubing - 250 mm
	HPT30-6	Tubo Alta Pressione / High Pressure Tubing - 300 mm

Raccordi per l'Alta Pressione / High Pressure Fittings	Codice / Code	Descrizione / Description
 0°  90°	HP00C-1/8x6	Raccordo Alta Pr / High Pr Fitting 0° - G1/8" - 250 bar
	HP90C-1/8x6	Raccordo Alta Pr / High Pr Fitting 90° - G1/8" - 250 bar

Tappo per l'Alta Pressione / High Pressure Plug	Codice / Code	Descrizione / Description
	P18-06	Tappo Alta Pressione / High Pressure Plug

Nuovo Sistema Troncatura,
Scanalatura e Taglio esterno



New system external Cutting,
Grooving and Parting-off

Profilatura
Profiling

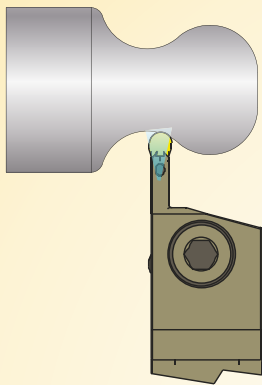

Tornitura e Scanalatura
Turning & Grooving

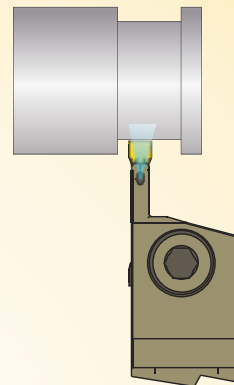

Taglio
Part-off

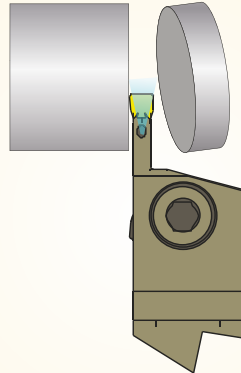

Scanalatura
Grooving

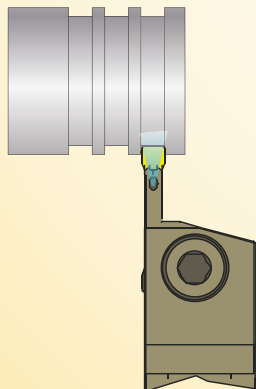

Tornitura
Turning

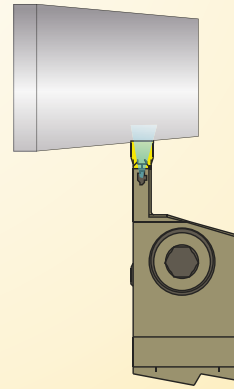

Lama per Troncare

Cutting Blades

LACG...

NEW

26-2

32-2

32-5

Lama di nuova concezione con INNOVATIVO sistema di bloccaggio inserti, veloce e pratico.
Blade with new design and innovative locking system inserts, fast and practical.

Inserto con nuovo rompitruciolo ad altissima efficienza.
Insert with new chip-breaker high efficiency.



VANTAGGI / ADVANTAGES

Sblocco rapido
Quick release



- maggiore produttività con inserti a 2 taglienti
Increased productivity with inserts with 2 cutting
- eccellente stabilità durante la lavorazione
excellent stability during machining
- finitura di qualità superiore
higher quality finishing
- nuovo sistema di bloccaggio facile e sicuro
new clamping system easy and secure
- marcatura su lama per riferimento visivo lavorazioni
marking on the blade for visual reference work

Tipi di lavorazione
Machining type



LACG...

Cutting blades
Lames a tronçonner
Abstechträger
Lamas para troncar

Lama per troncare

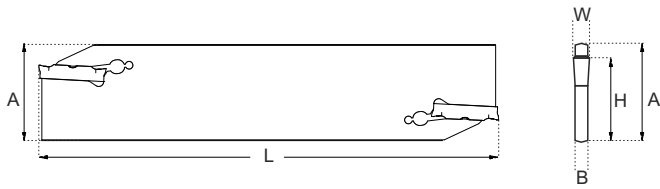

Codice Code	Dimensioni / Dimensions					Inserito Insert	Parti di ricambio / Spare parts
	A	W	H	B	L		
LACG 26-2	26	2	21.4	1.6	110	CTSN 22-20...	CLG-475
LACG 26-3	26	3	21.4	2.4	110	CTSN 22-30...	CLG-475
LACG 26-4	26	4	21.4	3.2	110	CTSN 25-40...	CLG-475
LACG 32-2	32	2	25	1.6	150	CTSN 22-20...	CLG-475
LACG 32-3	32	3	25	2.4	150	CTSN 22-30...	CLG-475
LACG 32-4	32	4	25	3.2	150	CTSN 25-40...	CLG-475
LACG 32-5	32	5	25	3.2	150	CTSN 25-50...	CLG-475

Tipo di lavorazione - Machining Types

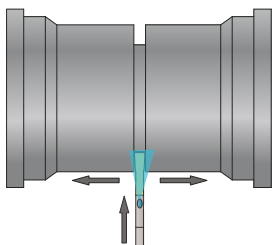

C x 5



L 2 - L 7



CEGR/L...

Holder for grooving and parting-off
 Porte plaquettes a rainurer et a tronçonner
 Klemmhalter zum Abstechen
 Utensilios para ranura y troncatura exterior

Utensili per scanalatura / troncatura esterna

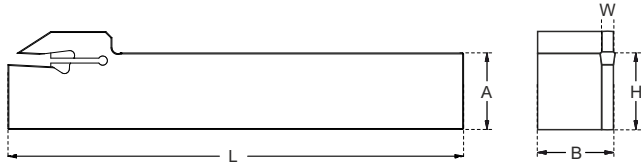

Codice Code	Dimensioni / Dimensions						Inserto Insert	Parti di ricambio / Spare parts	
	A	B	H	L	W	T max			
CEGR/L 1616K 20-10	16	16	16	125	2.0	10	CTSN 22-20..	VB0520	CBR40
CEGR/L 1616K 25-12	16	16	16	125	2.5	12	CTSN 22-25..	VB0520	CBR40
CEGR/L 1616K 30-14	16	16	16	125	3.0	14	CTSN 22-30..	VB0520	CBR40
CEGR/L 2020K 20-12	20	20	20	125	2.0	12	CTSN 22-20..	VB0520	CBR40
CEGR/L 2020K 25-14	20	20	20	125	2.5	14	CTSN 22-25..	VB0520	CBR40
CEGR/L 2020K 30-18	20	20	20	125	3.0	18	CTSN 22-30..	VB0520	CBR40
CEGR/L 2020K 40-20	20	20	20	125	4.0	20	CTSN 25-40..	VB0520	CBR40
CEGR/L 2020K 50-22	20	20	20	125	5.0	22	CTSN 25-50..	VB0620	CBR50
CEGR/L 2525M 20-12	25	25	25	150	2.0	12	CTSN 22-20..	VB0520	CBR40
CEGR/L 2525M 25-14	25	25	25	150	2.5	14	CTSN 22-25..	VB0520	CBR40
CEGR/L 2525M 30-18	25	25	25	150	3.0	18	CTSN 22-30..	VB0520	CBR40
CEGR/L 2525M 40-20	25	25	25	150	4.0	20	CTSN 25-40..	VB0520	CBR40
CEGR/L 2525M 50-22	25	25	25	150	5.0	22	CTSN 25-50..	VB0620	CBR50
CEGR/L 2525M 60-24	25	25	25	150	6.0	24	CTSN 25-60..	VB0620	CBR50
CEGR/L 3232P 30-18	32	32	32	170	3.0	18	CTSN 22-30..	VB0520	CBR40
CEGR/L 3232P 40-20	32	32	32	170	4.0	20	CTSN 25-40..	VB0520	CBR40
CEGR/L 3232P 50-22	32	32	32	170	5.0	22	CTSN 25-50..	VB0620	CBR50
CEGR/L 3232P 60-24	32	32	32	170	6.0	24	CTSN 25-60..	VB0620	CBR50

Tipo di lavorazione - Machining Types

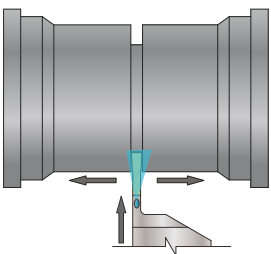

C x 5



L 2 - L 7



CIGR/L...

Holder for internal grooving
 Porte plaquettes a rainurer interieur
 Klemmhalter zum Abstechen
 Utensilios para ranura interior

Utensili per scanalatura interna

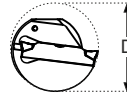
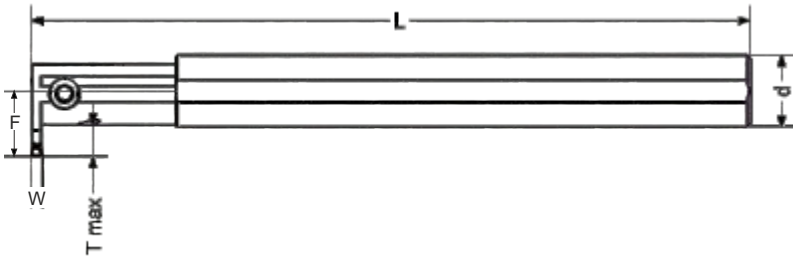

Codice Code	Dimensioni / Dimensions						Inserto Insert	Parti di ricambio / Spare parts	
	D	d	F	L	W	T max			
CIGR/L 0020Q 20	25	20	14	180	2.0	7	CTSN 22-20..	VB0512	CBR40
CIGR/L 0020Q 30	25	20	14	180	3.0	7	CTSN 22-30..	VB0512	CBR40
CIGR/L 0020Q 40	28	20	17	180	4.0	9	CTSN 25-40..	VB0512	CBR40
CIGR/L 0025R 20	32	25	18	200	2.0	9	CTSN 22-20..	VB0516	CBR40
CIGR/L 0025R 30	32	25	18	200	3.0	9	CTSN 22-30..	VB0516	CBR40
CIGR/L 0025R 40	32	25	18	200	4.0	9	CTSN 25-40..	VB0516	CBR40
CIGR/L 0032S 30	38	32	22	250	3.0	11	CTSN 22-30..	VB0516	CBR40
CIGR/L 0032S 40	38	32	22	250	4.0	11	CTSN 25-40..	VB0516	CBR40
CIGR/L 0032S 50	38	32	22	250	5.0	11	CTSN 25-50..	VB0516	CBR40

C x 5

L 2 - L 7





CESR/L...

Holder for external grooving
 Porte plaquettes a rainurer extérieur
 Klemmhalter zum Abstechen
 Utensilios para ranura exterior

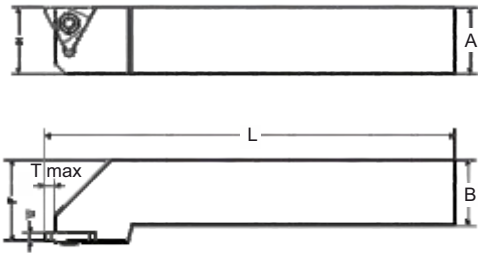
Utensili per scanalatura esterna



Codice Code	Dimensioni / Dimensions						Inserito Insert	Parti di ricambio / Spare parts	
	A-B	F	H	L	W	T max			
CESR/L 1616H 16	16	21	16	100	1.1-3.15	2.5	SG 16-..	TX3508	CTX10
CESR/L 2020K 16	20	25	20	125	1.1-3.15	2.5	SG 16-..	TX3508	CTX10
CESR/L 2525M 16	25	32	25	150	1.1-3.15	2.5	SG 16-..	TX3508	CTX10

Tipo di lavorazione - Machining Types

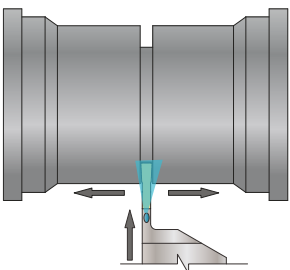

C x 6



L 2 - L 7





CISR/L...

Holder for internal grooving
 Porte plaquettes a rainurer interieur
 Klemmhalter zum Abstechen
 Utensilios para ranura interior

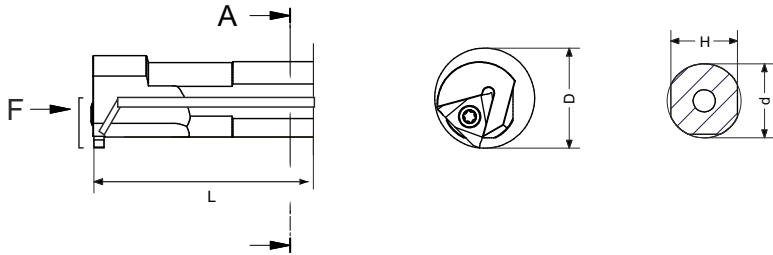
Utensili per scanalatura interna



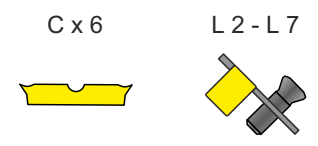

Codice Code	Dimensioni / Dimensions						Inserto Insert	Parti di ricambio / Spare parts	
	D	d	F	L	W	T max			
CISR/L 0016M 16	23	16	10,8	150	1.1-3.15	2.5	SG 16-..	TX3508	CTX10
CISR/L 0020Q 16	25	20	11,0	180	1.1-3.15	2.5	SG 16-..	TX3508	CTX10
CISR/L 0025R 16	30	25	14,5	200	1.1-3.15	2.5	SG 16-..	TX3508	CTX10

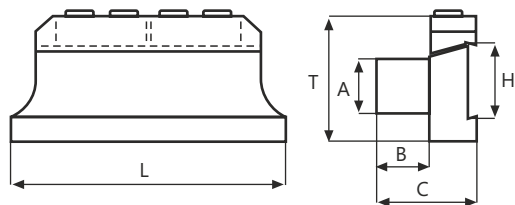

PLC...

Portalama

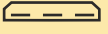

Codice Code	Dimensioni / Dimensions						Parti di ricambio / Spare parts		
	H	A	B	C	L	T			
PLC 16-19	19	16	16	33	80	33	STL19	VB6020	CBR50
PLC 16-26	26	16	16	34	80	40	STL2616	VB6020	CBR50
PLC 20-26	26	20	19	38	90	42	STL26	VB6020	CBR50
PLC 20-32	32	20	19	38	120	48	STL32	VB6020	CBR50
PLC 25-26	26	25	23	42	90	43	STL26	VB6020	CBR50
PLC 25-32	32	25	23	42	120	48	STL32	VB6020	CBR50

L 2 - L 7



SGIH...

Cutting blades with stop
Lames a tronçonner avec stop
Abstechträger mit Anschlag
Lamas para troncar con stop

Lama per troncare con stop

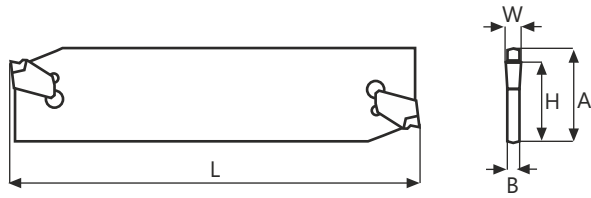

Codice Code	Dimensioni / Dimensions					Inserto Insert	Parti di ricambio / Spare parts
	A	W	H	B	L		
SGIH 19-2	19	2	16	1.6	85	GT..2	CLT5
SGIH 26-2	26	2	21.4	1.6	110	GT..2	CLT5
SGIH 26-3	26	3	21.4	2.4	110	GT..3	CLT5
SGIH 26-4	26	4	21.4	3.2	110	GT..4	CLT5
SGIH 26-5	26	5	21.4	4	110	GT..5	CLT5
SGIH 26-6	26	6	21.4	5.2	110	GT..6	CLT5
SGIH 32-2	32	2	25	1.6	150	GT..2	CLT5
SGIH 32-3	32	3	25	2.4	150	GT..3	CLT5
SGIH 32-4	32	4	25	3.2	150	GT..4	CLT5
SGIH 32-5	32	5	25	4	150	GT..5	CLT5
SGIH 32-6	32	6	25	5.2	150	GT..6	CLT5
SGIH 32-8	32	8	25	7.2	150	GT..8	CLT5
SGIH 32-9	32	9	25	8	150	GT..9	CLT5

Tipo di lavorazione - Machining type

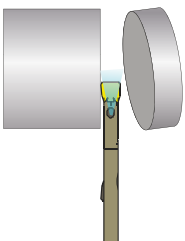

C x 6



L 2 - L 7



LA...

Cutting blades
Lames a tronçonner
Abstechträger
Lamas para troncar

Lama per troncare

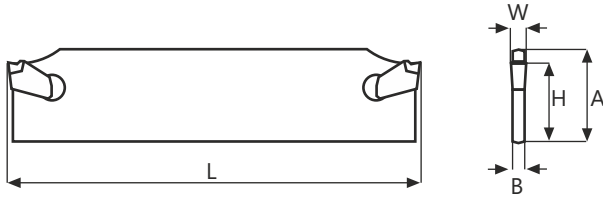

Codice Code	Dimensioni / Dimensions					Inserto Insert	Parti di ricambio / Spare parts
	A	W	H	B	L		
LA 085192	19	2	16	1.6	85	GT..2	CLT5
LA 110262	26	2	21.4	1.6	110	GT..2	CLT5
LA 110263	26	3	21.4	2.4	110	GT..3	CLT5
LA 110264	26	4	21.4	3.2	110	GT..4	CLT5
LA 110265	26	5	21.4	4	110	GT..5	CLT5
LA 110266	26	6	21.4	5.2	110	GT..6	CLT5
LA 150322	32	2	25	1.6	150	GT..2	CLT5
LA 150323	32	3	25	2.4	150	GT..3	CLT5
LA 150324	32	4	25	3.2	150	GT..4	CLT5
LA 150325	32	5	25	4	150	GT..5	CLT5
LA 150326	32	6	25	5.2	150	GT..6	CLT5
LA 150328	32	8	25	7.2	150	GT..8	CLT5
LA 150329	32	9	25	8	150	GT..9	CLT5

Tipo di lavorazione - Machining type

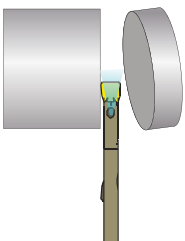

C x 6



L 2 - L 7



Inserti - Dati Tecnici

Inserts - Technical Data

Plaquettes - Données Techniques

Wendeschneidplatten - Technischen Daten

Insertos - Datos Tecnicos

Informazioni tecniche

Technical hints

Il nuovo sistema di designazione Comand delle qualità si basa su un codice semplice ed internazionale che permette di scegliere il materiale da taglio in base alle norme ISO.

The new Comand designation system constitutes a simple internationally comprehensible key. According to ISO standards, it describes the cutting material in application-oriented way.

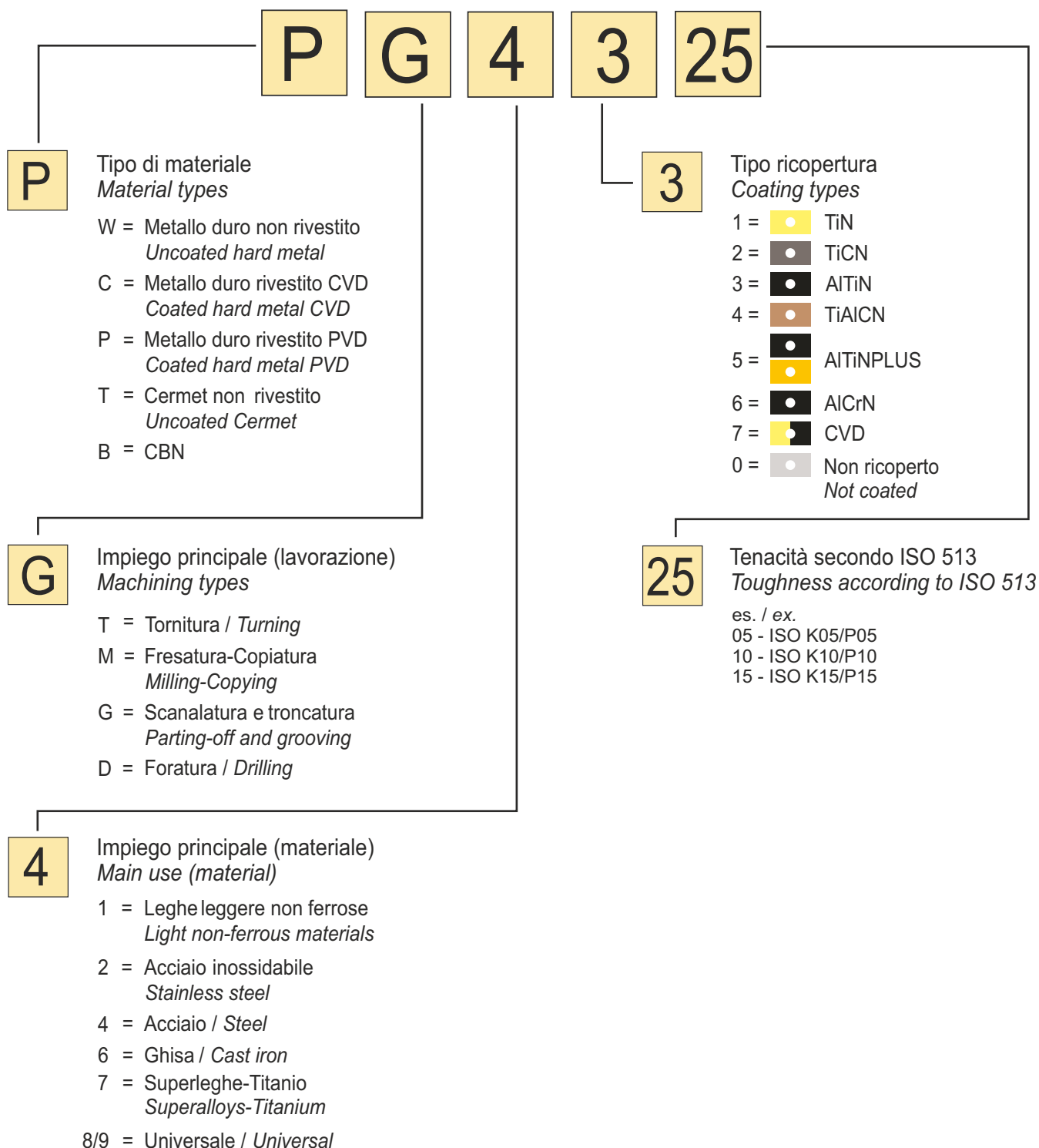

Qualità - Qualities

Codice Code	DIN ISO 513		Materiale / Material						Rivestimento Coating	Colore Color
			P	M	K	N	S	H		
CG4125	HC	P25 M25	■		▣				CVD	●
PG4135	HC	P35	■	▣					PVD	●
PG4325	HC	P25 M25	■	▣	▣				PVD	●
PG4345	HC	P40 M40	■	■	▣				PVD	●
PG4525	HC	P25	■	▣	▣	▣	▣		PVD	●
PG4540	HC	P40	■	■	▣	▣	▣		PVD	●

Applicazione Consigliata
Recommended Application

Applicazione Possibile
Possible Application

Colore Inserto
Insert Color

P Acciai / Steels

M Acciai Inox / Stainless Steels



K Ghisa / Cast Iron

N Leghe Alluminio / Aluminium

S Resistenti al Calore / Heat Resistant

H Temprati / Hardened

Rompitrucioli - Chip Breakers

Codice Code	Utilizzo / Use			Velocità avanzamento / Feed speed f_n (mm/rot)					Materiale / Material					
	Finitura Finishing	Media Medium	Sgrossatura Roughing	F_n min		F_n max			P	M	K	N	S	H
				Larghezza inserto / Insert width										
				2.0	3.0	4.0	5.0	6.0						
CTSN-R...-GF 	•	•		0,10 0,30	0,15 0,35	0,17 0,38	0,20 0,40	■	▣	▣	▣	▣		
CTSN-...-GP 		•	•	0,05 0,15	0,10 0,20	0,12 0,23	0,15 0,28	■	■	▣				
CTSN-...-GT 	•	•	•	0,05 0,13	0,07 0,18	0,10 0,20	0,12 0,23	0,15 0,25	■	■	▣	▣	▣	

● Utilizzo Consigliato
Recommended Use



○ Utilizzo Possibile
Possible Use

■ Applicazione Consigliata
Recommended Application

▣ Applicazione Possibile
Possible Application

MATERIALI - MATERIALS		HB	f_z (mm)	a_p (mm)	Velocità di Taglio - Cutting Speed - V_c m/min						
					PG4345	PG4525	PG4540				
P	ACCIAIO NON LEGATO - NOT ALLOY STEEL	120-300			80-150	80-200	80-180				
	ACCIAIO LEGATO - ALLOY STEEL	180-350			70-120	60-180	60-150				
	ACCIAIO ALTO LEGATO - HIGH ALLOY STEEL	300-330			60-100	50-150	50-120				
M	INOX AUSTENITICO - DUPLEX - STAINLESS STEEL	180-230			80-150	60-150	50-150				
K	GHISA GRIGIA - GREY CAST IRON	120-260			90-180	100-200	100-200				
	GHISA SFEROIDALE - SPHEROIDAL CAST IRON	160-250			100-150	100-180	100-180				
	GHISA MALLEABILE - MALLEABLE CAST IRON	130-230			100-80	80-160	80-160				
N	ALLUMINIO E SUE LEGHE - ALUMINIUM	60-130				300-400	200-300				
	RAME E SUE LEGHE - COPPER	90-110									
	NON METALLICI - PLASTICS										
S	LEGHE RESIST. AL CALORE - HIGH TEMP. ALLOY	200-320				30-50	20-40				
	TITANIO E SUE LEGHE - TITANIUM	400-1050									

Rompitrucioli - Chip Breakers

Codice Code	Utilizzo / Use			Velocità avanzamento / Feed speed fn (mm/rot)		Materiale / Material					
	Finitura Finishing	Media Medium	Sgrossatura Roughing	F _n min	F _n max	P	M	K	N	S	H
				→							
GTN...-GM GTR/L...-GM 		•	•	0,05 - 0,3		■	▣	▣			
SG...-GF 	•			0,05 - 0,3		■	■	▣			

● Utilizzo Consigliato
Recommended Use





○ Utilizzo Possibile
Possible Use

■ Applicazione Consigliata
Recommended Application

▣ Applicazione Possibile
Possible Application

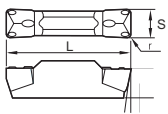
MATERIALI - MATERIALS		HB	fz (mm)	ap (mm)	Velocità di Taglio - Cutting Speed - Vc m/min					
					CG4125	PG4135	PG4325			
P	ACCIAIO NON LEGATO - NOT ALLOY STEEL	120-300			90-160	80-140	110-190			
	ACCIAIO LEGATO - ALLOY STEEL	180-350			90-140	60-120	110-180			
	ACCIAIO ALTO LEGATO - HIGH ALLOY STEEL	300-330			100-130	60-90	80-170			
M	INOXAUSTENITICO - DUPLEX - STAINLESS STEEL	180-230				40-120	50-150			
K	GHISA GRIGIA - GREY CAST IRON	120-260					90-180	90-180		
	GHISA SFEROIDALE - SPHEROIDAL CAST IRON	160-250					100-160	100-160		
	GHISA MALLEABILE - MALLEABLE CAST IRON	130-230					100-200	100-200		
N	ALLUMINIO E SUE LEGHE - ALUMINIUM	60-130								
	RAME E SUE LEGHE - COPPER	90-110								
	NON METALLICI - PLASTICS									
S	LEGHE RESIST. AL CALORE - HIGH TEMP. ALLOY	200-320						30-50		
	TITANIO E SUE LEGHE - TITANIUM	400-1050								

Inserti - Inserts

TRONCATURA PARTING-OFF	Materiale Material	Acciaio - Steel					P				■	■	■			
		Acciaio inox - Stainless steel					M				■	■	■			
		Ghisa - Cast iron					K				■	■	■			
		Leghe leggere - Aluminium alloys					N					■	■			
		Resistenti al calore - Heat resistant					S					■	■			
Materiali temprati - Hardened material					H											
	Codice di ordinazione Ordering code	Dimensioni - Size					HC Ricoperti - Coated						HW Non Ricoperti Uncoated			
		L	d	S	F	r	CG4125	PG4135	PG4325	PG4345	PG4525	PG4540				
	CTSN-R...-GF	CTSN 22-30-GF R1.5	22		3.0	1.5							●			
		CTSN 25-40-GF R2.0	25		4.0	2.0							●			
		CTSN 25-50-GF R2.5	25		5.0	2.5							●			
		CTSN 25-60-GF R3.0	25		6.0	3.0							●			
	CTSN-...-GP	CTSN 22-20-GP	22		2.0	0.2							●			
		CTSN 22-30-GP	22		3.0	0.2							●			
		CTSN 25-40-GP	25		4.0	0.4							●			
		CTSN 25-50-GP	25		5.0	0.4							●			
	CTSN-...-GT	CTSN 22-20-GT	22		2.0	0.2								●		
		CTSN 22-30-GT	22		3.0	0.2								●		
		CTSN 25-40-GT	25		4.0	0.4								●		
		CTSN 25-50-GT	25		5.0	0.4								●		
		CTSN 25-60-GT	25		6.0	0.4								●		





■ Applicazione Consigliata
Recommended Application

▣ Applicazione Possibile
Possible Application

● Disponibile
In stock

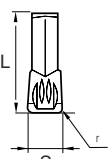
○ A richiesta
On request

Inserti - Inserts

TRONCATURA <i>PARTING-OFF</i>	Materiale <i>Material</i>	Acciaio - Steel					P	■	■	■						
		Acciaio inox - Stainless steel					M		■	■						
		Ghisa - Cast iron					K	■		■						
		Leghe leggere - Aluminium alloys					N									
		Resistenti al calore - Heat resistant					S									
		Materiali temprati - Hardened material					H									
	Codice di ordinazione Ordering code	Dimensioni - Size					HC Ricoperti - Coated						HW Non Ricoperti Uncoated			
		L	d	S	F	r	CG4125	PG4135	PG4325	PG4345	PG4525	PG4540				
GTN...-GM 	GTN 2-GM	9.3	-	2.2	-	0.15	●		●							
	GTN 3-GM	11.3	-	3.1	-	0.20	●		●							
	GTN 4-GM	11.3	-	4.1	-	0.20	●		●							
	GTN 5-GM	11.4	-	5.1	-	0.30	●									
	GTN 6-GM	11.4	-	6.1	-	0.30	●									
	GTN 8-GM	13.5	-	8.1	-	0.50	●									
	GTN 9-GM	13.5	-	9.6	-	0.50	●									
GTR/L...-GM 	GTR 2-GM	9.3	-	2.2	-	0.15	●									
	GTR 3-GM	11.3	-	3.1	-	0.20	●									
	GTR 4-GM	11.3	-	4.1	-	0.20	●									
	GTL 2-GM	9.3	-	2.2	-	0.15	●									
	GTL 3-GM	11.3	-	3.1	-	0.20	●									
	GTL 4-GM	11.3	-	4.1	-	0.20	●									
SG...-GF 	SG16 110-GF	16	9.52	1.10	3.80			●								
	SG16 130-GF	16	9.52	1.30	3.80			●								
	SG16 160-GF	16	9.52	1.60	3.80			●								
	SG16 185-GF	16	9.52	1.85	3.80			●								
	SG16 215-GF	16	9.52	2.15	3.80			●								
	SG16 265-GF	16	9.52	2.65	3.80			●								
	SG16 300-GF	16	9.52	3.00	3.80			●								
	SG16 315-GF	16	9.52	3.15	3.80			●								

■ Applicazione Consigliata
Recommended Application

▣ Applicazione Possibile
Possible Application

● Disponibile
In stock

○ A richiesta
On request

